

Attachment 1

Conceptual Conservation and Reclamation Plan Figures

S:\GIS\Projects\CE\KNOC_BlackGold\CE03746_EIA\Draw\Section 03 - Conceptual Conservation and Reclamation\Fig01-01\Fig01-01 x-sec CPF.cdr

PRE-DISTURBANCE PHASE

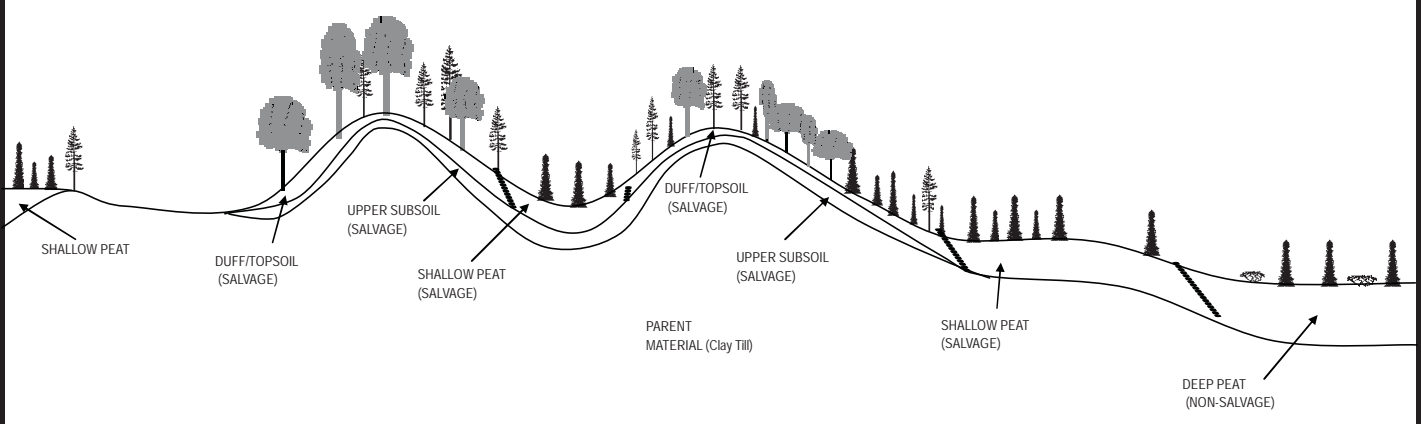

OPERATIONS PHASE

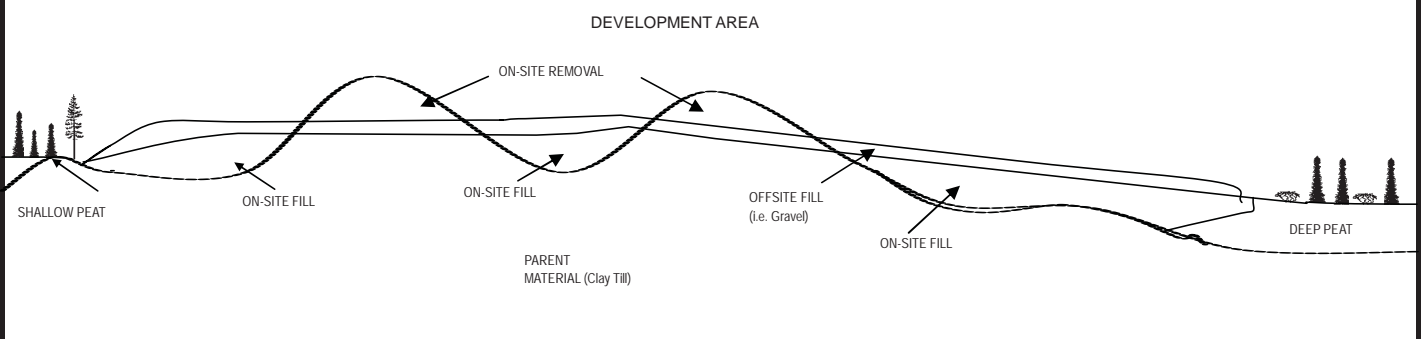

RECLAMATION PHASE

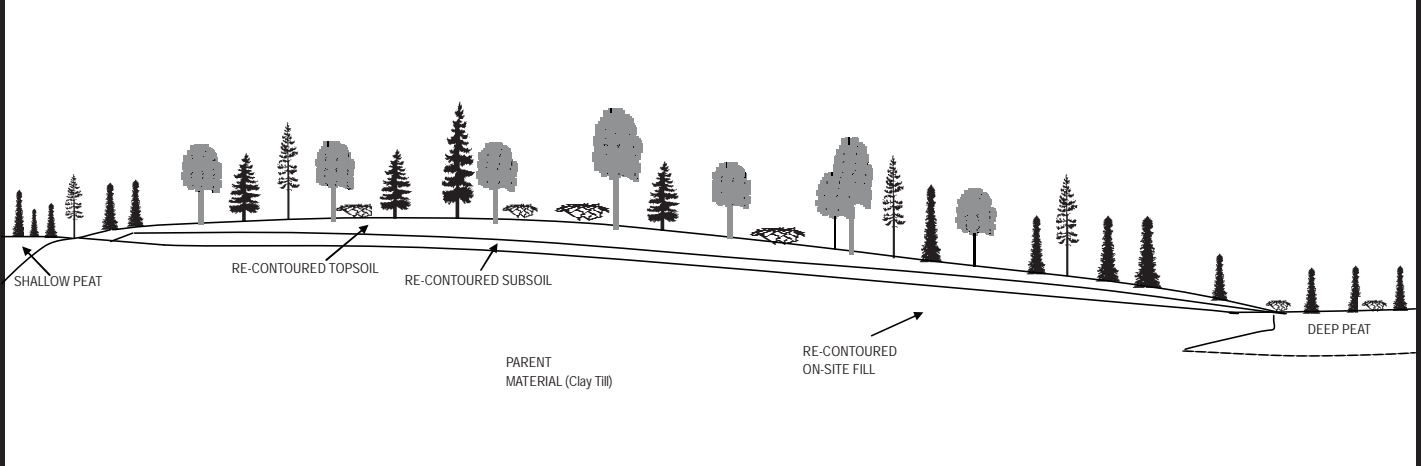

Note: Not to scale



Korea National Oil Corporation
BlackGold Expansion Project

**Conceptual Cross-section
 Central Plant Facility**

DATE: December 2009	
PROJECT: CE03745\800	
ANALYST: KW	QA/QC: KW DH DR

Fig01-01 x-sec CPF 09-12-09
DRAWN BY: AMEC
PREPARED BY: AMEC

**Attachment
 Figure
 1-1**

PRE-DISTURBANCE PHASE

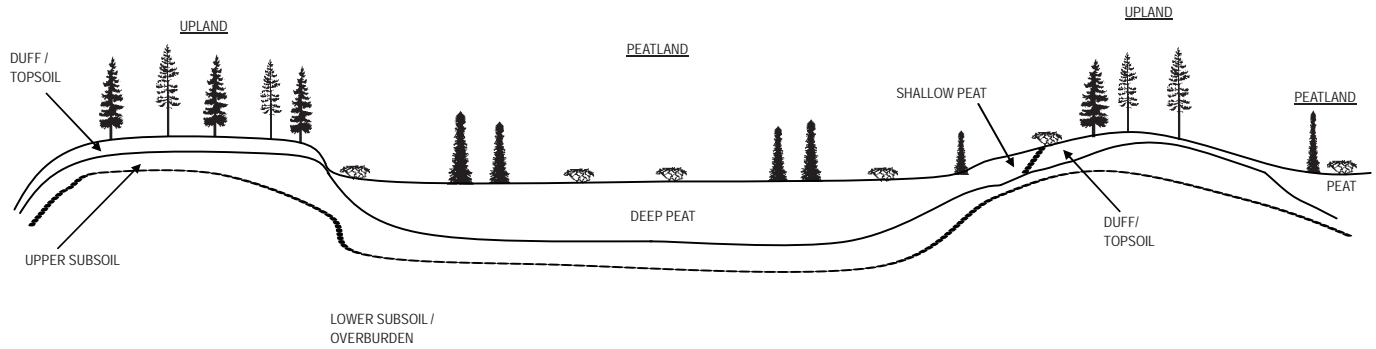

OPERATIONS PHASE

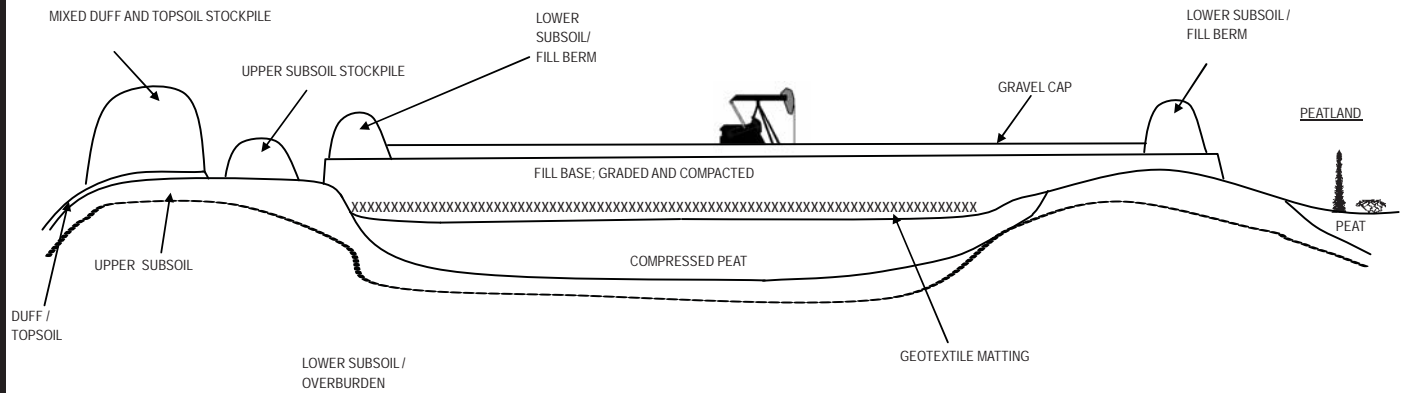

RECLAMATION PHASE

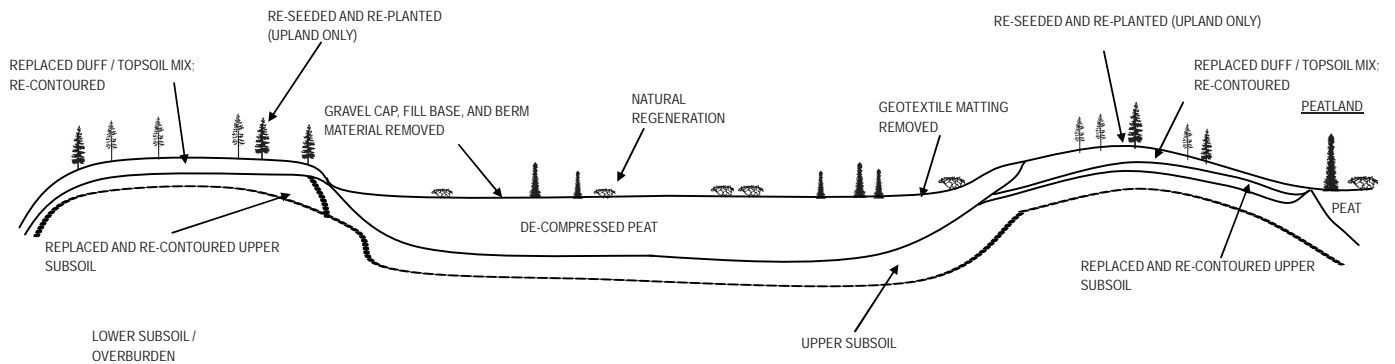

Note: Not to scale

S:\GIS\Projects\CE\KNOC_BlackGold\CE03746_EIA\Draw\Section 03 - Conceptual Conservation and Reclamation\Fig01-02\Fig01-02 x-sec Wellpad.cdr



Korea National Oil Corporation
BlackGold Expansion Project

Conceptual Cross-section of Well Pad

DATE: December 2009			
PROJECT: CE03745\800			
ANALYST: KW	QA/QC: KW	DH	DR

Fig01-02 x-sec Wellpad 09-12-09	
DRAWN BY: AMEC	
PREPARED BY: AMEC	

Attachment Figure 1-2

PRE-DISTURBANCE PHASE

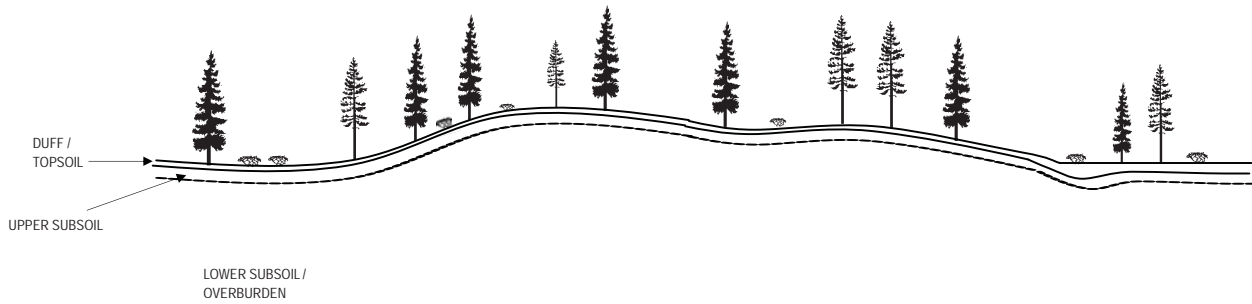

OPERATIONS PHASE

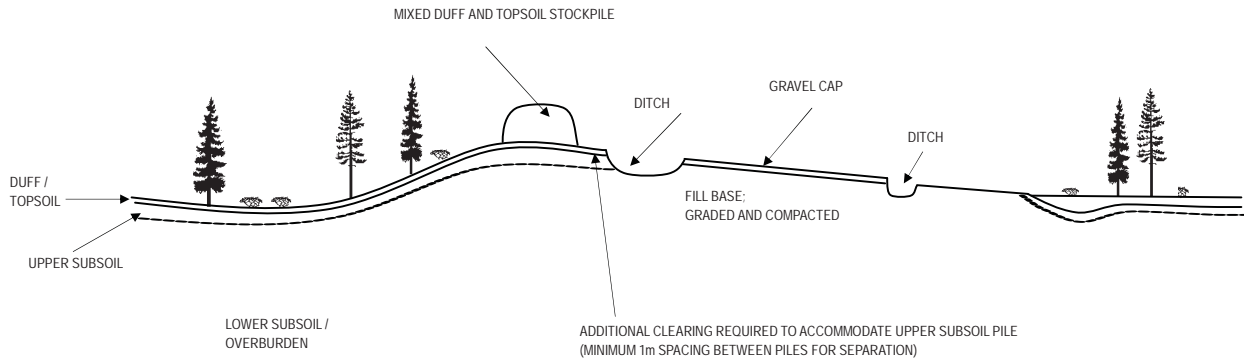

RECLAMATION PHASE

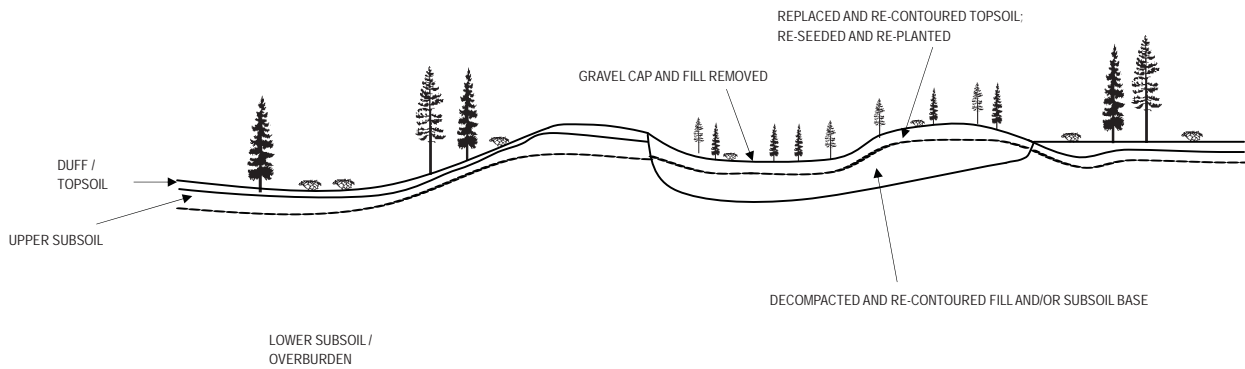

Note: Not to scale

S:\GIS\Projects\CE\KNOOC_BlackGold\CE03746_EIA\Draw\Section 03 - Conceptual Conservation and Reclamation\Fig01-04\Fig01-04 x-sec Road UA.cdr



Korea National Oil Corporation
BlackGold Expansion Project

Conceptual Cross-section
Road Development in Upland Areas
(End View)

DATE: December 2009			
PROJECT: CE03745\800		DRAWN BY: AMEC	
ANALYST: KW	QA/QC: KW	DH	DR

Fig01-04 x-sec Road UA 09-12-09	
DRAWN BY: AMEC	
PREPARED BY: AMEC	

Attachment Figure 1-4

S:\Gis\Projects\CE\KNOC_BlackGold\CE03745_EIA\DrawSection 03 - Conceptual Conservation and Reclamation\Fig01-05 x-sec Road Side.cdr

PRE-DISTURBANCE PHASE

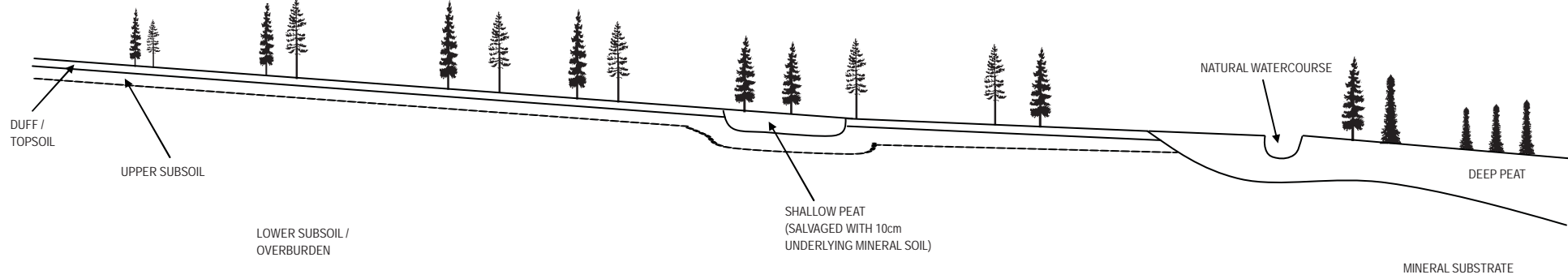

OPERATIONS PHASE

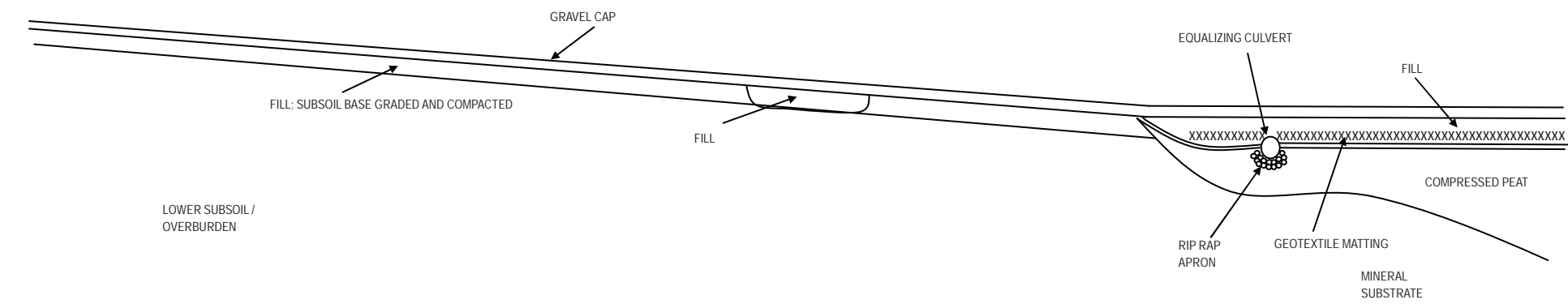

RECLAMATION PHASE

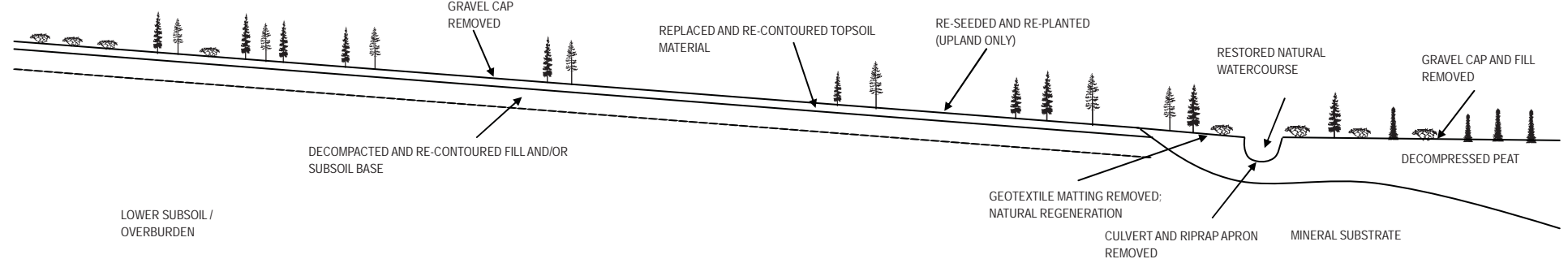

Korea National Oil Corporation
BlackGold Expansion Project

Road Development
 (Side View)

DATE: December 2009		Fig01-05 x-sec Road Side 09-12-09	
PROJECT: CE03745/800		DRAWN BY: AMEC	
ANALYST: KW	QA/QC: KW DH DR	PREPARED BY: AMEC	

Attachment
Figure
1-5

Attachment 2

Consultation

Attachment 2-1

Plain Language Summary



BlackGold Project – Expansion Project Plain Language Summary: July 2009

Introduction

Korea National Oil Corporation (KNOC) continues to evaluate the potential of oil sands leases, located approximately 10 km southeast of Conklin, Alberta. This document describes KNOC's preliminary plans to expand operations in the BlackGold Project area. The proposed Expansion Project will be located adjacent to and integrated with KNOC's Initial Project. KNOC holds a 100% working interest in 15 sections of land that make up the leases in Tp76, R7, W4M.

KNOC has identified sufficient oil sands reserves to support an additional 3,180 m³/d (20,000 b/d) project. Engineering studies are underway to determine the final capacity of the new project and to utilize the benefits of pre-investment in the Initial Project.

KNOC is committed to sustainable economic development and the involvement of the community from the earliest stages of project planning. The consultation process for the Expansion Project will build on KNOC's ongoing co-operative approach established with the stakeholders. KNOC encourages all stakeholders and aboriginal communities to contact the company to request additional information and to provide input and ideas.

Corporate Profile

KNOC was founded by the Korean government in 1979 to explore for and develop international petroleum resources. KNOC established an office in Alberta in 2006 and presently has ten employees in Alberta, all based in Calgary. Currently the company has no oil and gas production in Canada. However, the company has undertaken exploration programs on its oil sands leases since 2006. The BlackGold project represents KNOC's first oil sands development in Alberta.

Preliminary Project Description

The Plan

KNOC continues to evaluate the development potential of the oil sands leases in the BlackGold area. Preliminary information shows the Expansion Project could produce 3,180 m³/d (20,000 b/d) for 25 years. Expansion Project development capital, yet to be finalized, will be slightly larger than that of the Initial Project.

In the planning of the BlackGold development, KNOC has begun with a small 10,000 b/d for the Initial Project, while recognizing that future expansions are probable. The Initial Project enabled KNOC to employ a pre-investment strategy which facilitates an easier integration of the Expansion Project. The approach also reduces plot area requirements and impacts of the expanded development in comparison to entirely separate projects.

The field development planned with the Expansion Project is compact and near the central processing facilities to minimize surface disturbance. Where practical, gathering and distribution lines will share the same Right of Ways (ROW) and pipe racks. The Expansion Project will initially require three pads containing 28 well pairs. Processing technology similar to the Initial Project will be used which enhances the integration. Additional surface disturbance will be minimized by making use of as much of the existing infrastructure and disturbances as possible.

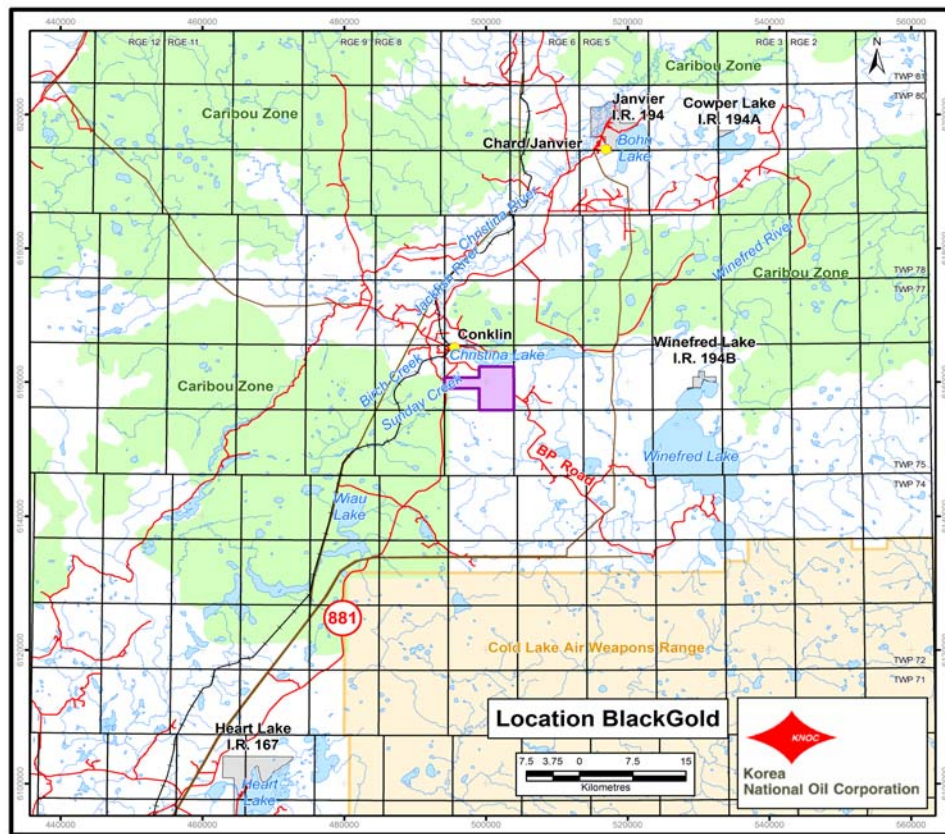

The Process

The Expansion Project will use Steam Assisted Gravity Drainage (SAGD) which is widely used in Alberta to access bitumen resources found in deposits too deep for commercial extraction using mining techniques. The SAGD process will use horizontal well pairs drilled directionally through the reservoir. The production well is drilled near the base of the reservoir and the steam injector is drilled about five meters above. Steam is injected into both wells until a steam chamber is established and thereafter, steam is injected into the upper well only, heating the bitumen. The heated bitumen then flows down to the production well along with the steam condensate and water is pumped to the surface through and ESP (Electric Submersible Pump) in each production well. Each well pair is expected to produce bitumen for nine years. After that time the wells are abandoned and new wells are drilled. Well pads no longer required for ongoing operation will be reclaimed to self-sustaining ecosystems. New well pads will be progressively added to maintain production rates.

Facilities

Project design at the conceptual level is ongoing. The produced bitumen and produced water will be transported to a central processing facilities via pipeline where the water will be treated and recycled back into the steam production facilities. The bitumen will be diluted and either trucked or piped to markets. The entire project disturbance area will be quite small in relation to the lease area. Multi-well pads and associated surface facilities will be designed and located to minimize environmental footprint.



Korea
National Oil Corporation

Project Schedule

Public consultation, project engineering and environmental impact assessment are underway to support company plans to file applications for the Expansion Project. KNOC anticipates filing an application to ERCB and AENV in late 2009 or early 2010. Project construction will commence only after regulatory approvals to proceed are obtained. The company anticipates approvals for the project in 2013.

Environmental Impact Assessment (EIA)

KNOC has assembled an EIA team to begin the important task of collecting baseline data, to assess the various impacts of the project in the local and regional setting. Topics include: traditional knowledge, historical resources, air, noise, groundwater, surface water, soil, vegetation, wildlife, fisheries, biodiversity, health and socio-economics. Draft Terms of Reference, describing the contents of the EIA, will be submitted to the regulators and made available for public review and commentary. Based on the comments received, Alberta Environment will issue the final Terms of Reference.

Public Engagement and Consultation

KNOC will continue to work with stakeholders and aboriginal groups. KNOC has been actively engaging and consulting with stakeholders and aboriginal groups since 2006. These efforts will be ongoing throughout the regulatory process and the lifecycle of the BlackGold Project. Stakeholders will be consulted through a series of individual meetings, public forums and written materials. All stakeholders and aboriginal communities are invited to contact KNOC with input and ideas at any time. Information provided to us and views expressed are very important, and these stakeholder communications will guide KNOC as the company moves towards development.

Contact Information

Please direct information requests about the project to either:

Mr. James (Hyunyong) Kim
Korea National Oil Corporation
2010, 520 – 5th Avenue S.W.
Calgary, Alberta T2P 3R7
Tel: 403-718-7082
Fax: 403-269-8081
Email: ppkitae@knoc.ca

or

Mr. Byeong-il Kim
Korea National Oil Corporation
2010, 520 – 5th Avenue S.W.
Calgary, Alberta T2P 3R7
Tel: 403-718-7081
Fax: 403-269-8081
Email: bikim85@knoc.ca



Korea
National Oil Corporation

Attachment 2-2

Project Summary Table

BlackGold Expansion Project Summary Table

Name of Company that will Hold Approval:	Korea National Oil Corporation	Company Contact Name and Information:	Byeong-il Kim Administration and Finance Manager Suite 2010 520 – 5 th Avenue SW Calgary, Alberta T2P 3R7 Tel: 403-718-7081 Fax: 403-269-8081 E-mail: bikim85@knoc.ca																											
Company Website:	www.knoc.co.kr/eng/index.php																													
Type of Project (e.g., in-situ, mine, quarry, upgrader, etc.)	In-situ, BlackGold Expansion Project																													
Types of Activity (major project processes)	<ul style="list-style-type: none"> • Central Processing Facilities • Powerline • Tankage • Saline water source wells, distribution and gathering lines 	New Project, Expansion or Modification:	Expansion																											
Project Location (legal land description) and Municipality:	Township 76, Range 7 West of the 4 th Meridian, Section 10 Regional Municipality of Wood Buffalo	Life of Project (# years, YYYY-YYYY):	Project life will be approximately 25 years. Project is proposed to be operational from 2015-2040																											
Average Production Capacity per Year (specify units):	20,000 b/d (3,180 m ³ /d)	Power Source (if on site power generation, describe quantity (MW) and facilities):	From grid																											
Nearest Residence (km):	Conklin, Alberta is approximately 10 km northwest from the proposed project site	Private or Public Land:	Public Land																											
Nearest First Nation Reserve(s) (name and km):	<table border="1" style="width: 100%; border-collapse: collapse;"> <thead> <tr> <th style="width: 30%;">First Nation</th> <th style="width: 30%;">Reserve</th> <th style="width: 40%;">Distance from KNOC lease (km)</th> </tr> </thead> <tbody> <tr> <td rowspan="3">Chipeywan Prairie Dene First Nation</td> <td>Winifred Lake 194B</td> <td>25</td> </tr> <tr> <td>Janvier 194</td> <td>35</td> </tr> <tr> <td>Cowper Lake 194A</td> <td>44</td> </tr> <tr> <td rowspan="2">Heart Lake First Nation</td> <td>Heart Lake 167</td> <td>58</td> </tr> <tr> <td>Heart Lake 167A</td> <td>66</td> </tr> <tr> <td rowspan="4">Fort McMurray #468 First Nation</td> <td>Gregoire Lake 176</td> <td>87</td> </tr> <tr> <td>Gregoire Lake 176A</td> <td>93</td> </tr> <tr> <td>Gregoire Lake 176B</td> <td>86</td> </tr> <tr> <td>Clearwater 175</td> <td>114</td> </tr> <tr> <td>Beaver Lake Cree Nation</td> <td>Beaver Lake 131</td> <td>106</td> </tr> </tbody> </table>	First Nation	Reserve	Distance from KNOC lease (km)	Chipeywan Prairie Dene First Nation	Winifred Lake 194B	25	Janvier 194	35	Cowper Lake 194A	44	Heart Lake First Nation	Heart Lake 167	58	Heart Lake 167A	66	Fort McMurray #468 First Nation	Gregoire Lake 176	87	Gregoire Lake 176A	93	Gregoire Lake 176B	86	Clearwater 175	114	Beaver Lake Cree Nation	Beaver Lake 131	106	Total Project Area (ha):	Approximately 2,000 ha
First Nation	Reserve	Distance from KNOC lease (km)																												
Chipeywan Prairie Dene First Nation	Winifred Lake 194B	25																												
	Janvier 194	35																												
	Cowper Lake 194A	44																												
Heart Lake First Nation	Heart Lake 167	58																												
	Heart Lake 167A	66																												
Fort McMurray #468 First Nation	Gregoire Lake 176	87																												
	Gregoire Lake 176A	93																												
	Gregoire Lake 176B	86																												
	Clearwater 175	114																												
Beaver Lake Cree Nation	Beaver Lake 131	106																												

BlackGold Expansion Project Summary Table

Total Area to be Disturbed (ha):	Approximately 150 ha	Infrastructure Requirements (roads, pipelines, water intake, storage, tankage):	<ul style="list-style-type: none"> • Existing roads • New pipeline • Saline ground water • Storage • Tankage
Method of Product Transport (e.g., pipeline, rail, truck):	Pipeline or truck	Project Products:	Project will produce 20,000 b/d of bitumen
Location of End Market:	Alberta pipeline system	Project By-products:	Project will produce approximately 100 t/d of sludge
Expected Types of Air Emissions (e.g., SO₂, NO_x, CO₂):	<ul style="list-style-type: none"> • SO₂ • NO₂ • PM_{2.5} • CO₂ 	Expected Types of Effluent Releases (note the waterbodies the effluent will be released to):	None
Types of Wastes Generated:	<ul style="list-style-type: none"> • Domestic sewage – septic field • Chemicals – no volumes available at this time • Filters – no volumes available at this time • Containers – no volumes available at this time • Caustic – 400 m³/yr 	Waste Management Facilities (i.e., disposal well, salt caverns, landfill or third party):	Third party landfill
Nearest Waterway/Waterbody (name and km):	Not applicable	Watercourse Crossings (type of crossing, any Class A to C waterbodies):	Unnamed Creek—no fish present—will be crossed by a clear span bridge
Water Act Licence Required (Y/N/Unknown/NA). If yes, purpose, source and estimated volumes):	No	Water Act Approval Required (Y/N/Unknown. If yes, purpose):	Yes
Fisheries Act Authorization Required (Y/N/Unknown):	No	Navigable Waters Protection Act Authorization Required (Y/N/Unknown):	No
Waterbodies Required (Y/N/Unknown/NA). If yes, number and ha):	No	Nearest Water Well (km) (domestic and commercial):	<p>Nearest domestic well is approximately 10 km away</p> <p>Nearest industrial water well is approximately 7 km away</p>
Nearest Provincial Highway (number and distance):	Highway 881 is the closest Provincial Highway, located approximately 6 km west of the proposed project	Access to Provincial Highway (no improv req/ improv req/ const req):	No improvements required

BlackGold Expansion Project Summary Table

Traffic Impact Assessment Required (Y/N/Unknown):	No	Pre-disturbance Land Use(s):	<ul style="list-style-type: none"> • Industrial gas wells • Traditional land use
Projected Construction Start (month/year):	late 2012 or early 2013	Project Operation Start (month/year):	2013
Reclamation Start and End (YYYY-YYYY):	Start: 2024 End: 2049	Post-reclamation Land Use(s):	Forestry, wildlife and recreation
Any Unique Environmental or Social Considerations (if yes, describe):	There are three rare plant locations in wetlands outside of the footprint.	Historic Resources Impact Assessment Required (Y/N/Unknown):	Yes
Estimated Construction Person-Years of Employment:	600	Estimated Operation Person-Years of Employment:	875
Construction or Operation Camp Required (Y/N/Unknown. If yes, on-site or off-site):	A construction and operation camp will be located on site	Method of Transport of Employees to Site (construction and operation):	Employees will access site via provided bussing or personal vehicle
Date Stakeholder Engagement Started (public/Aboriginal):	2006	Aboriginal Groups Involved in Stakeholder Engagement:	<ul style="list-style-type: none"> • Chipewyan Prairie Dene First Nation • Fort McMurray #468 First Nation • Heart Lake First Nation • Beaver Lake Cree Nation • Conklin Metis Local #193 • Fort McMurray Metis Local #1935 • Chard Metis Local #214 • Metis Nation of Alberta Zone 1



Korea
National Oil Corporation

Attachment 2-3

Summary of Consultation Activities

Summary of Public Engagement and Consultation Activities to November 15, 2009

Participant	Date	Method	Discussion Points
Beaver Lake Cree Nation	February 7, 2008	Meeting	<ul style="list-style-type: none"> Beaver Lake Cree Nation Intergovernmental Affairs and Industry Relations Office outlined the process that they would like KNOC to follow in undertaking their consultation activities. Beaver Lake Cree Nation Intergovernmental Affairs and Industry Relations Office committed to send their consultation policy to KNOC.
	February 9, 2008	Email	<ul style="list-style-type: none"> Beaver Lake Cree Nation Intergovernmental Affairs and Industry Relations Office sent a copy of their Consultation Policy and Monitoring Agreements to KNOC.
	May 8, 2008	Email	<ul style="list-style-type: none"> KNOC sent email to Beaver Lake Cree Nation Intergovernmental Affairs and Industry Relations Office, explaining that KNOC had reviewed the BLCN Consultation Policy and Monitoring Agreement and that KNOC would like to work with the BLCN to make changes to the Monitoring Agreement. KNOC suggested that they could revise the agreement and then present it to the BLCN to make changes, or meet with the BLCN to discuss suggested changes. The email requested the BLCN identify their preferred approach.
	May 13, 2008	Telephone	<ul style="list-style-type: none"> KNOC called Beaver Lake Cree Nation Intergovernmental Affairs and Industry Relations Office to discuss the preferred approach of the BLCN for revising the Draft Monitoring Agreement. Beaver Lake Cree Nation Intergovernmental Affairs and Industry Relations Office replied that they would contact KNOC during the week of May 19, 2008 to determine if a meeting could be arranged with KNOC in Calgary.
	May 20, 2008	Telephone	<ul style="list-style-type: none"> Beaver Lake Cree Nation Intergovernmental Affairs and Industry Relations Office and KNOC spoke about the process for advancing to agreement on the Monitoring Agreement which the BLCN provided to KNOC; and it was agreed that KNOC would send a revised draft agreement to Beaver Lake Cree Nation Intergovernmental Affairs and Industry Relations Office.
	July 22, 2008	Email	<ul style="list-style-type: none"> KNOC sent Beaver Lake Cree Nation Intergovernmental Affairs and Industry Relations Office a revised Monitoring Agreement and requested that they contact KNOC to discuss the document.
	July 23, 2008	Telephone	<ul style="list-style-type: none"> KNOC left a voicemail following up on the Monitoring Agreement that Beaver Lake Cree Nation Intergovernmental Affairs and Industry Relations Office sent by email on July 22, 2008.
	July 29, 2008	Telephone	<ul style="list-style-type: none"> KNOC called to speak with Beaver Lake Cree Nation Intergovernmental Affairs and Industry Relations Office. KNOC was told that Beaver Lake Cree Nation Intergovernmental Affairs and Industry Relations Office representative was on vacation.
	August 11, 2008	Telephone	<ul style="list-style-type: none"> KNOC called to speak Beaver Lake Cree Nation Intergovernmental Affairs and Industry Relations Office. KNOC was told that Beaver Lake Cree Nation Intergovernmental Affairs and Industry Relations Office representative was on vacation until August 21, 2008.

Participant	Date	Method	Discussion Points
Beaver Lake Cree Nation (cont)	August 20, 2008	Telephone	<ul style="list-style-type: none"> Beaver Lake Cree Nation Intergovernmental Affairs and Industry Relations Office called and explained several representatives of the Beaver Lake Cree Nation would be in Calgary, from August 26, 2008 to August 28, 2008 and wanted to take the opportunity to meet with KNOC. Beaver Lake Cree Nation Intergovernmental Affairs and Industry Relations Office explained that the BLCN was aware that KNOC would want to proceed with their development plans soon and just wanted to talk about what KNOC had planned and develop a consultation plan. KNOC asked if Beaver Lake Cree Nation Intergovernmental Affairs and Industry Relations Office had reviewed the revised Consultation Agreement that KNOC had sent on July 22, 2008. Beaver Lake Cree Nation Intergovernmental Affairs and Industry Relations Office explained that they had reviewed it and that would be one of the things that they wanted to speak with KNOC about.
	August 22, 2008	Telephone	<ul style="list-style-type: none"> It was agreed that a meeting of KNOC and BLCN representatives would be held on August 27, 2008.
	August 27, 2008	Meeting	<ul style="list-style-type: none"> The Beaver Lake Cree Nation representatives explained that the Beaver Lake Cree Nation has a right to be consulted about the project and do not support the Alberta Government Consultation Guidelines. The Beaver Lake Cree Nation also explained that they have revised the Consultation Agreement and will send it to KNOC, because they cannot accept the draft that KNOC sent. They explained that the Consultation Agreement will include provision for KNOC to pay the Beaver Lake Cree Nation to participate in the consultation process. The Beaver Lake Cree Nation representatives explained that consultation must occur throughout the entire lifecycle of the project. KNOC explained their 2008/2009 winter works program.
	September 2, 2008	Email	<ul style="list-style-type: none"> KNOC legal counsel email to BLCN legal counsel.
	September 9, 2008	Fax	<ul style="list-style-type: none"> Beaver Lake Cree Nation sent a revised consultation agreement.
	September 15, 2008	Email	<ul style="list-style-type: none"> KNOC legal counsel received email from BLCN legal counsel.
	September 16, 2008	Telephone	<ul style="list-style-type: none"> KNOC legal counsel discussion with BLCN legal counsel.
	September 24, 2008	Meeting	<ul style="list-style-type: none"> KNOC legal counsel meeting with BLCN legal counsel.
	September 30, 2008	Telephone	<ul style="list-style-type: none"> Benson Salloum Watts LLP representative (Beaver Lake Cree Nation legal council) called KNOC representative to determine if KNOC would be willing to meet in Kelowna on October 2 or October 3, 2008 to discuss the Monitoring Agreement.
	October 1, 2008	Telephone	<ul style="list-style-type: none"> KNOC legal council called to speak with Benson Salloum Watts LLP to explain that KNOC would not be able to participate in meetings on October 2 or 3, 2008. It was agreed that KNOC legal council and BLCN legal council would have a without prejudice discussion during the week of October 6, 2008 to advance discussions on the monitoring agreement.
	October 16, 2008	Telephone	<ul style="list-style-type: none"> KNOC legal council and BLCN legal council had a privileged and confidential discussion.
	October 20, 2008	Telephone	<ul style="list-style-type: none"> KNOC representative called to speak with Beaver Lake Cree Nation about the winter and water programs.

Participant	Date	Method	Discussion Points
Beaver Lake Cree Nation (cont)	October 24, 2008	Telephone/Email	<ul style="list-style-type: none"> • KNOC representative called to speak with Beaver Lake Cree Nation about the winter and water programs. • KNOC representative sent email providing a project description of the proposed winter and water programs, and requested a call to discuss these further.
	October 28, 2008	Telephone	<ul style="list-style-type: none"> • Beaver Lake Cree Nation phoned to say that the BLCN and KNOC were negotiating a consultation agreement for the commercial SAGD project and suggested that consultation on the water and winter program could not proceed until that agreement was signed. • KNOC representative explained the need to consult on the winter and water programs prior to agreement for the commercial SAGD project, due to timelines.
	October 29, 2008	Meeting	<ul style="list-style-type: none"> • KNOC legal counsel meeting with BLCN legal counsel regarding draft agreement.
	October 30, 2008	Telephone	<ul style="list-style-type: none"> • Beaver Lake Cree Nation representative phoned to state that they would not discuss any KNOC related issues until a consultation agreement was signed.
	November 6, 2008	Meeting	<ul style="list-style-type: none"> • KNOC legal council and BLCN legal council had a privileged and confidential discussion.
	November 24, 2008	Email	<ul style="list-style-type: none"> • KNOC representative sent email explaining that KNOC would be requesting approval from Alberta Sustainable Resource Development for the proposed winter and water programs.
	December 2, 2008	Letter	<ul style="list-style-type: none"> • BLCN legal council sent letter to KNOC legal council which contained some background on the policies, procedures and initiatives that the Beaver Lake Cree Nation would like to undertake.
	December 16, 2008	Letter	<ul style="list-style-type: none"> • BLCN legal council sent letter to KNOC legal council stating that he was awaiting a response to the letter sent on November 26, 2008.
	February 9, 2009	Meeting	<ul style="list-style-type: none"> • BLCN legal council and KNOC legal council had a privileged and confidential discussion.
	February 9, 2009	Letter	<ul style="list-style-type: none"> • KNOC legal council sent letter to BLCN legal council. • Letter confirms that KNOC received Beaver Lake Cree Nation document entitled Consultation and Monitoring Project, and that KNOC will not have any comments on the document. • Letter also stated that in meeting on November 9, 2008 meeting that BLCN would send a revised version of Schedule B to KNOC and that KNOC should not comment until seeing the revised version of Schedule B and that BLCN legal council had confirmed to send Schedule B to KNOC by February 24, 2009.
	February 16, 2009	Emailed letter	<ul style="list-style-type: none"> • Beaver Lake Cree Nation Intergovernmental Affairs and Industry Relations Office sent letter. • Letter informs all proponents applying for projects within the Nation's Traditional Territory that they will be required to provide an administration and technology fee for \$250.00 per application.
	March 23, 2009	Letter	<ul style="list-style-type: none"> • KNOC legal counsel letter to BLCN legal counsel.
	March 25, 2009	Telephone	<ul style="list-style-type: none"> • KNOC legal counsel discussion with BLCN legal counsel.
	April 8, 2009	Meeting	<ul style="list-style-type: none"> • KNOC legal counsel meeting with BLCN legal counsel.
May 19, 2009	Emailed Letter	<ul style="list-style-type: none"> • Beaver Lake Cree Nation Intergovernmental Affairs and Industry Relations Office sent letter. • Letter requested funding for Beaver Lake Cree Nation Annual Pow Wow. 	

Participant	Date	Method	Discussion Points
Beaver Lake Cree Nation (cont)	June 8, 2009	Emailed Letter	<ul style="list-style-type: none"> Beaver Lake Cree Nation legal council sent letter indicating that Beaver Lake Cree Nation was upset that KNOC had reported consultations had occurred when only discussions regarding development of a consultation plan had occurred. Letter indicated that prospective relations between KNOC and Beaver Lake Cree Nation were endangered and requested that KNOC display an appropriate level of respect and engage in meaningful discussions.
	June 12, 2009	Emailed Letter	<ul style="list-style-type: none"> KNOC legal council sent letter to Beaver Lake Cree Nation legal council. Letter indicated that KNOC is committed to fully engaging and consulting the Beaver Lake Cree Nation and will continue to work with them. KNOC indicated that they reported activities and progress which have occurred to date. Letter indicated that KNOC is committed to advancing the consultation agreement and will provide draft during the week of June 15, 2009.
	June 15, 2009	Telephone	<ul style="list-style-type: none"> KNOC legal counsel discussion with BLCN legal counsel.
	June 17, 2009	Emailed Letter and Draft Agreement	<ul style="list-style-type: none"> KNOC legal council sent Beaver Lake Cree Nation legal council a cover letter and draft consultation agreement.
	July 7, 2009	Email	<ul style="list-style-type: none"> KNOC legal counsel received email from BLCN legal counsel with attached draft agreement.
	July 15, 2009	Telephone	<ul style="list-style-type: none"> KNOC legal counsel discussion with BLCN legal counsel.
	July 17, 2009	Telephone	<ul style="list-style-type: none"> KNOC legal council called Beaver Lake Cree Nation legal council to discuss the revised consultation agreement.
	July 24, 2009	Telephone	<ul style="list-style-type: none"> KNOC legal counsel discussion with BLCN legal counsel.
	July 28, 2009	Telephone	<ul style="list-style-type: none"> KNOC legal Council and BLCN legal council discussed the Consultation Agreement.
	August 13, 2009	Email	<ul style="list-style-type: none"> KNOC legal council sent email to BLCN legal council.
	August 20, 2009	Telephone	<ul style="list-style-type: none"> BLCN legal council called KNOC legal council to provide an update on their review of the revised consultation agreement.
	September 1, 2009	Email	<ul style="list-style-type: none"> KNOC legal council and BLCN legal council exchanged emails regarding the draft Consultation Agreement.
	September 2, 2009	Email	<ul style="list-style-type: none"> KNOC legal council and BLCN legal council exchanged emails regarding the draft Consultation Agreement.
	September 2, 2009	Telephone	<ul style="list-style-type: none"> KNOC legal council and BLCN legal council had telephone discussion regarding draft Consultation Agreement.
	September 15, 2009	Email	<ul style="list-style-type: none"> BLCN legal council sent email regarding draft Consultation Agreement.
September 15, 2009	Fax	<ul style="list-style-type: none"> Beaver Lake Cree Nation sent fax to ERCB regarding consultation status update that KNOC provided to ERCB. The fax indicated that Beaver Lake Cree Nation was disappointed with the manner in which KNOC characterised their engagement and consultation activities with the Beaver Lake Cree Nation. 	
September 24, 2009	Telephone	<ul style="list-style-type: none"> KNOC legal counsel discussion with BLCN legal counsel. 	

Participant	Date	Method	Discussion Points
Beaver Lake Cree Nation (cont)	October 6, 2009	Email	<ul style="list-style-type: none"> BLCN legal council sent email regarding draft Consultation Agreement.
	October 7, 2009	Telephone	<ul style="list-style-type: none"> KNOC legal council called BLCN legal council to discuss draft Consultation Agreement.
	October 7, 2009	Email	<ul style="list-style-type: none"> BLCN legal council sent email containing draft Consultation Agreement.
	October 8, 2009	Email	<ul style="list-style-type: none"> BLCN legal council and KNOC legal council exchanged emails regarding draft consultation agreement.
	October 14, 2009	Telephone	<ul style="list-style-type: none"> KNOC legal counsel discussion with BLCN legal counsel
	October 20, 2009	Telephone	<ul style="list-style-type: none"> KNOC legal council called BLCN legal council to discuss draft consultation agreement.
	October 26, 2009	Telephone	<ul style="list-style-type: none"> KNOC legal council called BLCN legal council to discuss draft consultation agreement.
	October 28, 2009	Email	<ul style="list-style-type: none"> BLCN legal council emailed KNOC legal council and indicated that the draft Consultation Agreement was not acceptable to the Beaver Lake Cree Nation. Email indicated that the agreement was not acceptable because amongst other things it prevents free and easy access to BLCN traditional lands.
	November 14, 2009	Email	<ul style="list-style-type: none"> KNOC emailed Beaver Lake Cree Nation Intergovernmental Affairs and Industry Relations Office. Email contained proposed Terms of Reference from Alberta Environment, public notice regarding the proposed Terms of Reference, plain language summary, and project summary sheet. Email explained KNOC's understanding that BLCN had rejected Consultation Agreement and does not want to engage with KNOC until a consultation agreement is signed. Email explained that KNOC is open to continuing negotiations on the consultation agreement.
	November 16, 2009	Letter	<ul style="list-style-type: none"> BLCN legal council sent letter to KNOC legal council.
December 1, 2009	Email	<ul style="list-style-type: none"> KNOC legal counsel review of email received from BLCN legal counsel 	
Chipewyan Prairie Dene First Nation	September – November 2007	Various	<ul style="list-style-type: none"> Various communications to coordinate meetings for project overview and advance the consultation process.
	November 21, 2007	Meeting	<ul style="list-style-type: none"> Met CPIRC Director while attending Open House with the Southern Athabasca Oilsands Producers and discussed KNOC project and need to hold meeting.
	November 27, 2007	Meeting	<ul style="list-style-type: none"> KNOC presented project overview. CPDFN agreed to provide consultation plan to KNOC, including a process for including TK and TLU into the assessment. CPDFN expressed interest in minimizing environmental effects and maximizing local business opportunities and community capacity building.
	February 20, 2008	Meeting	<ul style="list-style-type: none"> Discussed consultation process and procedures for joining the CPIRC.
	February 21, 2008	Emails and calls	<ul style="list-style-type: none"> CPIRC sent information to KNOC regarding membership in IRC.

Participant	Date	Method	Discussion Points
Chipewyan Prairie Dene First Nation (cont)	February 22, 2008	Email	<ul style="list-style-type: none"> • CPIRC sent email suggesting that KNOC should join the CPIRC as a full member. The email contained attachments, including the IRC bilateral agreement, the TEK sharing agreement, the 2007 funders matrix, and the CPDFN Consultation Process.
	March 27, 2008	Meeting	<ul style="list-style-type: none"> • This was a meeting organized by the CPIRC for industry funders. • Prior to the meeting, KNOC provided the CPIRC with a hard copy of the application submitted to AENV and the ERCB for 10,000 bpd. • Several CPIRC members were available. The CPDFN presented the CPIRC Budget and the industry partners commented on the budget.
	April 4, 2008	Telephone	<ul style="list-style-type: none"> • KNOC called CPIRC to discuss the submission of the Phase 1 application. • CPIRC described the process that the CPDFN will use to complete their third party review of the Phase 1 application.
	May 6, 2008	Telephone	<ul style="list-style-type: none"> • KNOC called CPIRC to discuss the status of the work plan related to the technical review of the Phase 1 application that the CPIRC had committed to providing. • CPIRC stated that EnerPlus is generating work plan templates that KNOC should contribute to by adding the work that they think will need to be undertaken, and then the CPIRC will also fill them in and agree to the steps that need to be undertaken. • CPIRC explained that they would meet with the Environmental Assessment experts for KNOC once MSES has reviewed the application to discuss environmental issues, socio-economic issues and business opportunities.
	June 17, 2008	Email	<ul style="list-style-type: none"> • MSES (consultant to CPDFN IRC) sent KNOC an email asking for a response to the scope of work to review the KNOC environmental report.
	July 14, 2008	Telephone/email	<ul style="list-style-type: none"> • KNOC called CPIRC and explained that MSES had sent an email requesting a response to the scope of work, but that KNOC had not yet received the scope of work. • CPIRC emailed KNOC: <ul style="list-style-type: none"> – the scope of work and budget for the third party review of the Phase 1 application; – the CPDFN Consultation Processes; – 2007 Funders Matrix; and – IRC Bilateral Agreement.

Participant	Date	Method	Discussion Points
Chipewyan Prairie Dene First Nation (cont)	July 16, 2008	Telephone/email	<ul style="list-style-type: none"> • KNOC confirmed to CPIRC that they had received the email and attachments which CPIRC sent on July 14, 2008. • KNOC explained that they would like to work with the CPIRC to produce a document which would outline the specific consultation activities that KNOC will need to undertake to satisfy the requirements of the CPIRC. KNOC explained that this document could be based on the CPDFN Consultation Processes document but focused specifically on the activities that KNOC should undertake, and include details such as when the activities should occur, and how much they will cost. • CPIRC explained that they would prepare the document and thought that it was a good idea. • KNOC sent CPIRC an email requesting an action plan that would satisfy the CPIRC Consultation requirements.
	July 29, 2008	Telephone	<ul style="list-style-type: none"> • KNOC called and spoke with CPIRC. KNOC explained that they were looking for the status of CPIRC Consultation Action Plan for the project. CPIRC explained that they would provide the plan before August 1, 2008.
	August 6, 2008	Telephone	<ul style="list-style-type: none"> • KNOC called to remind CPIRC that they had committed to providing KNOC with a Consultation Action Plan on August 1, 2008 and that KNOC had not yet received the plan. • CPIRC explained that they would not be able to send the plan until August 12, 2008
	August 27, 2008	Telephone/email	<ul style="list-style-type: none"> • CPIRC phoned and explained their understanding that KNOC had been provided with the agreement to join the IRC and was disappointed that KNOC had not joined the IRC yet. • CPIRC also explained that the CPDFN wanted to file a Statement of Concern about the project because KNOC had not yet joined the IRC. • KNOC explained that the period to file a Statement of Concern had passed, but that KNOC wants to work with the CPIRC to resolve any concerns. • CPDFN sent email with three attachments including the: <ul style="list-style-type: none"> • – IRC Bilateral Agreement 2007; • – 2007 funders matrix Final; and • – KNOC CPDFN Consultation Process final.
	September 4, 2008	Email	<ul style="list-style-type: none"> • KNOC confirmed that they had received the IRC bilateral agreement and suggested some minor revisions. KNOC explained that once the revisions were received, KNOC would sign the agreement and sent it and the IRC fees to the Chipewyan Prairie Dene First Nation Industry Relations Corporation.
	September 8, 2008	Email	<ul style="list-style-type: none"> • The CPIRC confirmed that they would alter the IRC Bilateral Agreement as per KNOC's request and send the revised version to KNOC.
	September 18, 2008	Email	<ul style="list-style-type: none"> • The CPIRC sent an email stating that the CPDFN insists on third party review and encourages KNOC to approve their proposal for a third party review.
	September 29,, 2008	Telephone	<ul style="list-style-type: none"> • KNOC and CPIRC discussed the CPDFN–KNOC IRC Agreement, the proposal to conduct a third party review, and the consultation process.

Participant	Date	Method	Discussion Points
Chipewyan Prairie Dene First Nation (cont)	October 1, 2008	Email	<ul style="list-style-type: none"> • CPIRC sent KNOC an email with the revised CPIRC Bilateral Agreement. • Email also explained that CPDFN is working to determine next steps regarding a traditional land use study and will get a work plan to KNOC as soon as they can. • Email was also sent to CPDFN Business development manager for Chipewyan Prairies Ventures asking that he contact KNOC regarding business opportunities.
	October 2, 2008	Telephone	<ul style="list-style-type: none"> • KNOC representative called CPIRC. KNOC representative explained that he wanted to confirm the IRC fees that KNOC would be required to pay. CPDFN representative explained the rate. KNOC representative asked why one of the rates quoted on the IRC agreement for another company that is also an associate member is considerably lower. CPDFN representative explained that the company was in a different phase of development and their project was located north of Fort McKay not in the Christina Lake area. • KNOC representative also explained the urgency in completing the third party review promptly and asked when the review could be complete.
	October 6, 2008	Email	<ul style="list-style-type: none"> • KNOC representative sent CPIRC representative and MSES Representative an email. • The email explained that KNOC had some questions and concerns about the proposal to complete a third party review. Specifically the email explained that consultation, biodiversity, traditional ecological knowledge and traditional resource use, and cumulative effects should not be addressed in the review for a variety of reasons.
	October 7, 2008	Email	<ul style="list-style-type: none"> • CPIRC responded to email sent by KNOC representative on October 6, 2008. • CPIRC agreed to remove consultation section on scope of work for third party review. • CPIRC provided rationale for including biodiversity, cumulative effects and traditional ecological knowledge and traditional land use in the third party review.
	October 21, 2008	Telephone	<ul style="list-style-type: none"> • KNOC representative phoned CPIRC office to discuss KNOC/OSE water program and winter drilling program. IRC office representative was unavailable. Requested that the call be returned.
	October 24, 2008	Telephone	<ul style="list-style-type: none"> • KNOC representative phoned CPIRC office to discuss KNOC/OSE water program and winter drilling program. IRC office representative was unavailable. Requested that the call be returned.
	October 24, 2008		<ul style="list-style-type: none"> • KNOC representative sent email with project description and requested a meeting to discuss the winter drilling program and water program.

Participant	Date	Method	Discussion Points
Chipewyan Prairie Dene First Nation (cont)	November 7, 2008	Email	<ul style="list-style-type: none"> • KNOC representative called CPIRC representative to explain that KNOC had approved the CPIRC agreement and to discuss the third party review. • KNOC representative sent signed IRC agreement to CPIRC with a note explaining that KNOC will send the original by mail, and requested that CPIRC representative sign the original and return it to KNOC. • KNOC representative sent email to CPIRC representative explaining that KNOC is prepared to proceed with the third party review and request that it be completed as soon as practical. • KNOC also requested a revised proposal which reflects the agreements which had been reached. KNOC representative called MSES and explained that he had spoken with CPIRC representative earlier in the day. KNOC representative explained that KNOC will fund the third party review and required a revised proposal based on the agreements that had been reached. MSES Representative agreed to revise the proposal and sent it to KNOC by November 12, 2008.
	November 20, 2008	Email	<ul style="list-style-type: none"> • KNOC representative sent email explaining that KNOC would be requesting approval from Alberta Sustainable Resource Development for the proposed winter and water programs.
	December 3, 2008	Email	<ul style="list-style-type: none"> • KNOC representative sent email to CPIRC representative stating that KNOC had agreed to the IRC Agreement and sent a signed version to the IRC. However, the IRC has not signed the agreement and sent a copy back to KNOC. The email stated that KNOC will pay IRC fees once the signed agreement is returned.
	December 4, 2008	Telephone	<ul style="list-style-type: none"> • KNOC representative phoned CPIRC representative to discuss the IRC Bilateral Agreement, the Third Party Review, and the Consultation Agreement. • CPDFN representative explained that CPDFN would send KNOC a signed copy of the IRC bilateral agreement. • CPIRC stated that the third party review should be completed and sent to KNOC the first week of January 2009. • CPIRC representative explained that the CPIRC wanted to focus on signing the bilateral agreement first, and will now make arrangements for an Elders tour.
	December 16, 2008	Telephone	<ul style="list-style-type: none"> • KNOC representative called CPIRC representative. • KNOC representative asked about the status of the third party review. CPIRC representative explained that it should be send to KNOC during the first or second week of January 2009. • KNOC representative discussed an invoice sent by MSES for expenses incurred in February 2008. There was some discussion about whether KNOC should pay this.
	December 17, 2008	Email	<ul style="list-style-type: none"> • MSES representative sent MSES's revised budget table to replace the previously submitted budget in the scope of work for completing a technical review of KNOC's regulatory application on behalf of the CPDFN IRC.
	December 18, 2008	Email	<ul style="list-style-type: none"> • KNOC representative replied to MSES's email December 17, 2008 and suggested further revisions to the revised budget.

Participant	Date	Method	Discussion Points
Chipewyan Prairie Dene First Nation (cont)	December 18, 2008	Email	<ul style="list-style-type: none"> • MSES representative replied to KNOC representative's email. Explained rationale for revised budget.
	January 19, 2009	Telephone	<ul style="list-style-type: none"> • KNOC and CPIRC representatives discussed the: <ul style="list-style-type: none"> – status of the third party review; – process for collected and documenting traditional knowledge and traditional land use for the KNOC BlackGold Project; and – need to sign environmental and socio-economic agreements.
	January 21, 2009	Telephone	<ul style="list-style-type: none"> • KNOC representative called to ask CPIRC about the status of the Third Party Review. CPDFN representative stated that MSES was finalizing the report and that it should be available shortly. • KNOC representative also asked about the status of the proposal to complete the traditional knowledge study. CPIRC representative explained that he had requested that FMA prepare the proposal, and that he would follow-up with them to determine the status.
	February 9, 2009	Telephone	<ul style="list-style-type: none"> • KNOC representative called to ask CPIRC about the status of the Third Party Review. CPDFN representative stated that MSES was finalizing the report and that it should be available shortly. • KNOC representative also asked about the status of the proposal to complete the traditional knowledge study. CPIRC representative explained that he had requested that FMA prepare the proposal, and that he would follow-up with them to determine the status.
	February 23, 2009	Email	<ul style="list-style-type: none"> • CPIRC representative sent an email. He explained in the email that: <ul style="list-style-type: none"> – he has received the third party review from MSES and committed to reviewing it and providing it to KNOC by March 1, 2009; and – agreed that it is required to agree to a plan for TLU work.
	March 16, 2009	Email	<ul style="list-style-type: none"> • CPIRC representative sent email containing letter dated March 16, 2009 from CPDFN to AENV and ERCB, and its third-party technical review of the project application. • The email also explained that the next steps will be for KNOC to review the report and generate responses to the questions, issues and concerns raised in the review, and comment and then meet with the CPDFN IRC to respond.
	May 3, 2009	Telephone	<ul style="list-style-type: none"> • KNOC and CPIRC representatives agreed to meet on May 28, 2009, and that KNOC would respond to results of third party review during the meeting. • CPIRC representative agreed to provide a proposal outlining the expected costs of the meeting to review the results of the third party review; and • CPIRC representative stated that the CPDFN will want to sign an environmental agreement with KNOC following the meeting to discuss the Third Party review.
	May 11, 2009	Email	<ul style="list-style-type: none"> • CPIRC sent email stating that the CPIRC would not be able to meet on the tentatively scheduled date of May 28, 2009 to discuss the results of the third party review.

Participant	Date	Method	Discussion Points
Chipewyan Prairie Dene First Nation (cont)	May 12, 2009	Email	<ul style="list-style-type: none"> • CPIRC representative sent email stating that CPIRC would not be able to meet with KNOG to discuss the results of the third party review until July 2, 2009.
	May 12, 2009	Telephone	<ul style="list-style-type: none"> • KNOG and CPIRC representatives discussed potential for meeting on July 2, 2009. • KNOG representative explained that KNOG would like to make progress sooner because the ERCB process is proceeding. • CPIRC representative recommended that KNOG negotiate Business Development and Community Investment Agreements with CPDFN.
	May 26, 2009	Telephone	<ul style="list-style-type: none"> • FMA representative left a voicemail for KNOG representative stating that FMA would supply CPIRC with a budget and scope for a traditional knowledge study that could be used by KNOG.
	May 27, 2009	Telephone	<ul style="list-style-type: none"> • KNOG representative returned FMA's telephone call and requested that she call again.
	May 27, 2009	Telephone	<ul style="list-style-type: none"> • FMA representative returned KNOG representatives call and left a voice mail.
	May 28, 2009	Telephone	<ul style="list-style-type: none"> • KNOG representative left a message for FMA representative requesting that she return the call.
	May 28, 2009	Telephone	<ul style="list-style-type: none"> • FMA representative returned KNOG representative's call. • FMA representative stated that she provided the Chipewyan Prairie First Nation with a proposal to complete a traditional knowledge study for the KNOG lease. She anticipates that they will review the proposal and provide her with comments on June 1, 2009. • FMA representative stated that the previous traditional knowledge study, which was completed by the Chipewyan Prairie Dene First Nation, was not very well done and that the information could not be relied on. She stated that much traditional knowledge information that is held by Chipewyan Prairie Dene First Nation members was not included in the original study.
	June 1, 2009	Telephone	<ul style="list-style-type: none"> • KNOG representative left a message with the receptionist for CPIRC representative to return the call.
	June 2, 2009	Email	<ul style="list-style-type: none"> • CPIRC representative sent KNOG representative email. The email: <ul style="list-style-type: none"> – acknowledged that CPDFN had received KNOG response to the CPDFN letter of March 16, 2009 and the MSES third party review; – suggested that the next step will be to schedule a meeting between MSES, the IRC and KNOG to review the response. The email also stated that MSES would submit a scope of work and budget for their participation in the meeting and to prepare for the meeting; – the email stated that MSES proposal would include cost for assisting the IRC is developing a plain language document that describes the project and that would be distributed throughout the community; – indicated that KNOG should begin discussions with the Director of the IRC, regarding social priorities and socio-economic agreements; and – the IRC will inform KNOG about the process that they want to use for TEK and TLU for the KNOG lease.
	June 3, 2009	Telephone	<ul style="list-style-type: none"> • KNOG representative left voicemail requesting that CPIRC representative return the telephone call.

Participant	Date	Method	Discussion Points
Chipewyan Prairie Dene First Nation (cont)	June 4, 2009	Telephone	<ul style="list-style-type: none"> • KNOC representative confirmed that he had received CPIRC email on June 2, 2009. • CPIRC representative asked if KNOC representative could forward an electronic version of KNOC's response to the third party review to him. It was originally sent to him hardcopy. KNOC representative confirmed that he would send an electronic version. • KNOC representative asked if CPIRC representative could confirm the CPDFN team's availability for the July 2, 2009 meeting to review the results of the third party review. CPIRC representative confirmed that he would speak with Director of the CPIRC and confirm their availability by June 8, 2009. • KNOC representative asked when KNOC could expect the proposal from MSES for attending the meeting and reviewing KNOC's response. CPIRC representative replied that KNOC would receive it within a week. • KNOC representative suggested that he and CPIRC representative could produce a plain language summary of the environmental assessment for the Initial Project and it would not be necessary to involve MSES. KNOC representative explained that KNOC was producing a plain language summary for Conklin. CPIRC representative agreed that it would not be necessary to involve MSES. KNOC representative asked if the CPIRC had a format or template in mind. CPIRC representative replied that he did not. KNOC representative offered to draft something for KNOC's project and then share it for comment. • CPIRC representative confirmed that FMA had provided him with a TEK proposal for the KNOC project and that he suggested to FMA that it be forwarded to KNOC representative. CPIRC representative stated that he would speak to FMA and ensure that it was sent.
	June 6, 2009	Telephone	<ul style="list-style-type: none"> • KNOC representative called CPIRC representative and left a voicemail requesting that he return the call. • KNOC representative explained that he was calling to confirm the meeting on July 2, 2009 to review the results of the third party review.
	June 10, 2009	Email	<ul style="list-style-type: none"> • CPIRC representative sent email suggesting that the meeting to discuss the third party review be postponed until the week of July 13, 2009.
	June 16, 2009	Email	<ul style="list-style-type: none"> • KNOC representative replied to CPIRC representative, stating that he had confirmed his team's availability for the week of July 13 to 17. KNOC representative explained that the meeting could occur anytime that week except July 13, 2009. He also suggested that the meeting date be confirmed before June 17, 2009.
	June 24, 2009	Telephone	<ul style="list-style-type: none"> • KNOC representative left a voicemail for CPIRC representative requesting that CPIRC representative call to confirm a meeting date for the third party review.
	June 29, 2009	Telephone	<ul style="list-style-type: none"> • KNOC representative called and spoke with CPIRC representative. • KNOC representative and CPIRC representative agreed that a meeting to discuss the results of the third party review would occur on July 14, 2009 from 9:00am to 5:00pm. It was also agreed that the meeting would occur at the AMEC boardroom in Calgary. • KNOC representative also explained that KNOC had not received the proposal for a traditional knowledge study from the CPIRC. CPIRC representative explained that he would speak with FMA representative at FMA and ensure that the proposal is sent. • KNOC representative explained that KNOC would like to speak about the benefits agreements and get some more definition about what the CPDFN would like included. CPIRC representative indicated that it might be possible to speak about those agreements on July 14, 2009.

Participant	Date	Method	Discussion Points
Chipewyan Prairie Dene First Nation (cont)	July 14, 2009	Meeting	<ul style="list-style-type: none"> The purpose of the meeting was to discuss the third party review of the environmental assessment completed for the BlackGold Project. KNOC representative explained that KNOC is aware that CPDFN does have concerns about potential environmental impacts of the project, and when practical KNOC wants to address those concerns. MSES representative explained that CPDFN is concerned about environmental effects, but also explained that they have additional goals and want to benefit from the project. KNOC representative explained that KNOC was anticipating that they would be able to help CPDFN achieve their goals through environmental, socio-economic and business agreements, and that discussion about those agreements were underway. KNOC representative explained that KNOC had intended to present a presentation that identified key concerns raised in the third party review and KNOC's responses. He asked CPIRC representative if that was appropriate. CPIRC representative replied that it was appropriate, as long as he and MSES representative could pose questions throughout the presentations. KNOC representative led the presentation entitled Korea National Oil Corporation BlackGold Project Chipewyan Prairie Dene First Nation SOC/Project Review Meeting'. Throughout the presentation CPIRC representative and MSES representative posed questions. CPIRC representative explained that he thought it was a useful and productive meeting.
	August 20, 2009	Email	<ul style="list-style-type: none"> KNOC representative emailed meeting notes from July 14, 2009 to CPIRC representative.
	August 20, 2009	Telephone	<ul style="list-style-type: none"> KNOC representative called CPIRC representative. CPIRC representative stated that he was in a meeting all day and requested that KNOC representative call in the morning of August 21, 2009.
	August 21, 2009	Telephone	<ul style="list-style-type: none"> KNOC representative called and left a voicemail for CPIRC representative to return the call.
	August 24, 2009	Telephone	<ul style="list-style-type: none"> KNOC representative called CPIRC representative to discuss the benefits agreement and the TK study proposal from FMA. CPIRC representative provided CPDFN Business Manager cell phone number to KNOC representative and suggested that KNOC contact him directly to discuss the business agreement for KNOC. KNOC representative and CPIRC representative talked about the traditional knowledge study proposal from FMA. CPIRC representative agreed that 7 to 10 interviews were appropriate and that 5 days would be the maximum amount of field days required. CPIRC representative also agreed that if the TK study could be initiated in the next few weeks, it could likely be completed by the end of October 2009. KNOC representative and CPIRC representative agreed to talk about the study further, likely on a conference call with FMA representative.
	August 24, 2009	Telephone	<ul style="list-style-type: none"> KNOC representative left a voice mail requesting that CPFN Business Manager return the call.

Participant	Date	Method	Discussion Points
Chipewyan Prairie Dene First Nation (cont)	August 25, 2009	Telephone	<ul style="list-style-type: none"> • KNOC representative called FMA representative to discuss the TK study proposal which was sent to KNOC. • KNOC representative explained that he had discussed the proposal with CPIRC representative, Environmental Coordinator, Chipewyan Prairie Industry Relations Corporation (CPIRC). • KNOC representative explained that CPFN IRC representative had indicated that that it was likely only 7 TK interviews would be required and suggested budgeting for about 10 interviews. • KNOC representative explained that due to the ground conditions and relatively small size of the lease, 5 days of ground truthing may not be required. He explained that the Elders for another First Nation indicated that they were not interested in doing ground truthing because of the ground conditions. • KNOC representative also stated that timing for the TK study is important and that KNOC would like the TK study completed by the end of October, to ensure that the results of the study could be incorporated into the environmental assessment for the BlackGold Project. FMA representative said that she thought it would be possible to complete the interviews and field verification in September, but it may not be able to complete the report writing by the end of October. • FMA representative requested that KNOC representative send an email documenting the discussion. • FMA representative agreed to send a revised proposal by August 31, 2009.
	August 25, 2009	Email	<ul style="list-style-type: none"> • KNOC representative sent email to FMA representative documenting the telephone discussion that had occurred earlier in the day.
	September 15, 2009	Email	<ul style="list-style-type: none"> • KNOC representative sent CPFN Business Manager an email requesting that he contact KNOC representative to advance discussions on potential business opportunities.
	October 14, 2009	Telephone	<ul style="list-style-type: none"> • KNOC representative called CPIRC representative. • KNOC representative explained that KNOC representatives have been trying to contact CPIRC representatives to arrange a meeting to discuss the benefits agreement. • CPFN IRC representative suggested that KNOC identify a few available dates. He suggested that the CPIRC would do the same and decide on a meeting date on October 15, 2009.
	October 15, 2009	Telephone	<ul style="list-style-type: none"> • KNOC representative and CPIRC representative agreed that representatives of KNOC and CPIRC would meet on September 26, 2009 in Fort McMurray to advance discussions about an impacts benefit agreement.
	October 15, 2009	Email	<ul style="list-style-type: none"> • KNOC representative sent email to CPIRC representative. • Email contained a Plain Language Summary and a Project Summary Table for the KNOC BlackGold Expansion Project. • Email also explained that KNOC will work with the CPDFN to develop a consultation plan.
	October 22, 2009	Email	<ul style="list-style-type: none"> • KNOC representative sent draft agenda for meeting on October 26, 2009 to CPIRC representative.
	October 23, 2009	Telephone	<ul style="list-style-type: none"> • KNOC representative called CPIRC representative to confirm that he had received the draft agenda for the meeting on October 26, 2009. • CPIRC representative confirmed that he had received the draft agenda. He also reviewed the agenda and indicated that he thought it was appropriate.

Participant	Date	Method	Discussion Points
Chipewyan Prairie Dene First Nation (cont)	October 23, 2009	Telephone	<ul style="list-style-type: none"> • KNOC representative called CPFN Business Manager. • KNOC representative asked about the upcoming CPDFN Trade Show, and whether it would be appropriate for KNOC to attend. • CPFN Business Manager replied that the purpose of the Trade Show was for the CPDFN Joint Venture companies and community member owned companies to present information to the oil and gas industry and for the industry to present information about their projects to community members. He explained that the Trade Show is scheduled for November 5, 2009. • CPFN Business Manager also provided some information on the Joint Venture companies and agreed to send information packages on the businesses. • It was also agreed that CPFN Business Manager and KNOC would arrange to meet in the near future.
	October 26, 2009	Meeting	<ul style="list-style-type: none"> • KNOC described the initial BlackGold Project, summarised the environmental assessment findings, described the engagement and consultation activities undertaken with the Chipewyan Prairie Dene First Nation to date, and described the proposed BlackGold Expansion Project. • KNOC explained that KNOC has been engaging and consulting with the Chipewyan Prairie Industry Relations Corporation for the past 3 years and indicated their willingness to sign a benefits agreement. CPIRC Director stated that the IRC staff indicated that they had a positive relationship with KNOC. • KNOC outlined the types of commitments that they would be prepared to make to the Chipewyan Prairie Dene First Nation. • KNOC requested that Chipewyan Prairie Dene First Nation withdrawal their statement of concern, or alter the statement of concern and withdrawal their request for a public hearing. • KNOC explained that there is some urgency from their perspective in getting approval for the initial BlackGold Project because they want to do some work this winter, or their project will be delayed for an entire year. • The CPIRC indicated that the Chipewyan Prairie Dene First Nation has a negotiating team and they would need to decide on the strategy for the Chipewyan Prairie Dene First Nation. • The CPIRC indicated that they would advance the proposal to the CPDFN negotiating team.
	October 28, 2009	Meeting	<ul style="list-style-type: none"> • KNOC met with the Chipewyan Prairie Dene First Nation negotiating team. • Chipewyan Prairie Dene First Nation described their negotiating position and committed to sending documents describing a framework agreement and proposed costs for negotiating an agreement. • KNOC indicated that their desire to reach an agreement and indicated that they would review the materials and respond. • KNOC also indicated that from their perspective the matter is urgent because they would like the CPDFN to withdrawal their request for a public hearing regarding the initial BlackGold Project. CPDFN indicated that they have a process that they would like to work through.
	October 30, 2009	Telephone	<ul style="list-style-type: none"> • CPFN Business Manager called KNOC representative and left a voicemail requesting that KNOC representative return the call.

Participant	Date	Method	Discussion Points
Chipewyan Prairie Dene First Nation (cont)	November 2, 2009	Email	<ul style="list-style-type: none"> • CPFN Business Manager sent email. • Email contained details on Janvier Reverse Trade Show. • Email indicated that industry would have the opportunity to provide information on their winter works program and project information current and planned. However, the email also indicated that ‘as the event is intended to be an opportunity to learn and share business opportunities with the community it is not to be used as consultation with the community or Chipewyan Prairie First Nation.
	November 3, 2009	Email	<ul style="list-style-type: none"> • KNOC representative sent email thanking CPFN Business Manager for the information about the Trade Show in Janvier and indicating that KNOC would attend.
	November 3, 2009	Email	<ul style="list-style-type: none"> • KNOC Representative sent email. • Email states that CPFN Chief Negotiator had indicated that he would forward a negotiation framework, fee schedule and preliminary budget to KNOC for consideration. Email indicated that KNOC representative had not yet received the email. • Email indicated that KNOC representative did not have contact information for CPFN Chief Negotiator and requested that CPIRC Director forward the email to CPFN Chief Negotiator, and provide contact information for Chief Negotiator.
	November 5, 2009	Trade Show	<ul style="list-style-type: none"> • Prior to the start of the Trade Show a CPFN Councillor provided KNOC representatives, and representatives from other companies, with a tour of Janvier. • KNOC had a booth at the CPDFN Reverse Trade Show. • KNOC provided a description of the KNOC BlackGold Project and the Expansion Project. Handouts were available to each trade show participant who visited the KNOC booth. A map of the proposed project was also available at the booth. • KNOC representatives spoke with CPDFN Chief and requested that CPDFN send letter to ERCB withdrawing their letter of objection to the BlackGold Project. The CPDFN Chief committed to calling KNOC representatives on November 6, 2009.
	November 9, 2009	Email	<ul style="list-style-type: none"> • KNOC representative sent email to CPDFN Business Manager. • Email contained a map showing the preliminary footprint of the BlackGold Project. • Email explained that tree clearing is all the work that KNOC is contemplating for 2009 – 2010 winter season. • Email explained that if KNOC receives regulatory approval for the project in 2009, then work would proceed in early 2010.
	November 11, 2009	Telephone	<ul style="list-style-type: none"> • KNOC representative and CPDFN Business representative arranged for a meeting on November 12, 2009.
	November 11, 2009	Telephone	<ul style="list-style-type: none"> • KNOC representative sent email confirming arrangements for November 12, 2009 meeting and provided directions to meeting.
	November 12, 2009	Email	<ul style="list-style-type: none"> • Operations Manager for Bear Slashing (a joint venture company of the CPDFN) sent email containing Turnkey bid and hourly rate schedule.
	November 12, 2009	Meeting	<ul style="list-style-type: none"> • CPDFN, CPIRC and KNOC met to discuss benefits agreement

Participant	Date	Method	Discussion Points
Chipewyan Prairie Dene First Nation (cont)	November 16, 2009	Telephone	<ul style="list-style-type: none"> • KNOC lawyer sent without prejudice and confidential letter to CPDFN lawyer. Email requested that letter be provided to CPDFN leadership.
	November 16, 2009	Telephone	<ul style="list-style-type: none"> • KNOC and CPDFN representatives discussed letter sent by KNOC lawyer earlier in the day. • CPDFN representative indicated a high level of frustration within CPDFN because they view themselves as paying the biggest price as a result of oilsands development and benefiting the least. • CPDFN representative indicated that they want guarantees that they will benefit from the KNOC BlackGold project. KNOC representative explained that they want to work with CPDFN businesses, and want CPDFN to benefit, but cannot guarantee them work. • CPDFN representative indicated that CPDFN has a strategy to approach major newspapers in New York, Washington, South Korea and Norway explaining how CPDFN is losing their heritage as a result of development.
	November 17, 2009	Telephone	<ul style="list-style-type: none"> • KNOC representative and CPDFN representative discussed a benefits agreement. No agreement was reached. • CPDFN representative indicated that CPDFN would like to meet with KNOC during week of November 23, 2009.
	November 18, 2009	Email	<ul style="list-style-type: none"> • KNOC representative sent email to CPDFN representative stating that KNOC would be available to meet in Calgary on November 24, or November 25, 2009.
	November 18, 2009	Telephone	<ul style="list-style-type: none"> • KNOC and CPDFN representatives agreed to a meeting on November 25.
	November 19, 2009	Email	<ul style="list-style-type: none"> • KNOC representative sent email responding to email from CPDFN IRC representative on November 18, 2009. • Email explained that KNOC agreed to join the IRC on October 21, 2008 and that the agreed upon budget period was from April 1, 2008 to March 31, 2009. KNOC representative explained that as a result it was not appropriate for the CPDFN to invoice for April 1, 2008 to March 31, 2008.
	November 20, 2009	Email	<ul style="list-style-type: none"> • CPDFN representative sent email requesting clarification about the permit/applications that KNOC would be applying for. Email suggested that in a previous conversation, the CPDFN asked what applications would be applied for. KNOC mentioned the application being reviewed by the ERCB, but the IRC also received notification on well and access roads.
	November 20, 2009	Email	<ul style="list-style-type: none"> • KNOC representative replied to email from CPDFN representative sent earlier on November 20, 2009. • KNOC representative explained that he had not interpreted CPDFN representatives question in the context of possible field work. He only considered the major applications and not applications for relatively minor field work. • KNOC representative outlined the major applications and suggested that current negotiations between KNOC and CPDFN should be focused on that application. He suggested that the routine applications should proceed as per the established process.
	November 24, 2009	Meeting	<ul style="list-style-type: none"> • KNOC representatives and CPDFN representatives met to discuss impacts benefits agreement. • No agreement was reached but a number of points required for an agreement were discussed.



Participant	Date	Method	Discussion Points
Chipewyan Prairie Dene First Nation (cont)	November 26, 2009	Email	<ul style="list-style-type: none"> • KNOC representative sent a Draft impact benefits agreement and commented upon the consultation document sent by the CPDFN.
	November 28, 2009	Telephone	<ul style="list-style-type: none"> • KNOC and CPDFN representatives discussed impact benefits agreement. KNOC and CPDFN effectively agreed to impact benefits agreement. CPDFN agreed to send letter of non-objection to ERCB regarding initial project.
	December 1, 2009	Email	<ul style="list-style-type: none"> • CPDFN sent letter of non-objection, regarding the initial project, to the ERCB
Fort McMurray #468 First Nation	September - November 2007	Emails and calls	<ul style="list-style-type: none"> • Various communications to coordinate future meetings for presentation of project overview and advance consultation process.
	January 18, 2007	Meeting	<ul style="list-style-type: none"> • Introduced KNOC and the project to the First Nation.
	November 28, 2007	Meeting	<ul style="list-style-type: none"> • KNOC presented project overview. • IRC Coordinator agreed to provide KNOC with a consultation plan. • KNOC representative presented 2008 OSE program. • IRC Coordinator expressed interest in business opportunities for band members and band owned companies.
	February 21, 2008	Telephone	<ul style="list-style-type: none"> • Introduced KNOC to the new IRC Director. • Explained that KNOC was waiting for consultation plan as previous IRC Director had committed to supplying. • IRC Director requested a meeting with KNOC.
	February 28, 2008	Email	<ul style="list-style-type: none"> • KNOC sent 'BlackGold SAGD Project Overview' to IRC Director. • KNOC requested IRC office advises them of when they would be available for a meeting. • KNOC requested the IRC send them documentation about the costs and benefits of joining the IRC.
	March 11, 2008	Telephone	<ul style="list-style-type: none"> • KNOC called IRC Director to confirm that she had received email sent on February 28, 2008. IRC Director confirmed she received email. • KNOC asked if a meeting was required, and when it could be arranged. • IRC Director responded that the soonest she could meet would be April 9 or April 10, 2008. • KNOC representative stated that they would confirm which day KNOC was able to meet.
	March 14, 2008	Email	<ul style="list-style-type: none"> • KNOC sent email to IRC Director stating that KNOC would appreciate meeting with her on April 9, 2008.
	March 17, 2008	Telephone	<ul style="list-style-type: none"> • KNOC called IRC Director to confirm meeting on April 9, 2008 and left a message.
	March 19, 2008	Telephone	<ul style="list-style-type: none"> • KNOC called IRC Director to confirm meeting on April 9, 2008 and left a message.
	March 26, 2008	Email	<ul style="list-style-type: none"> • IRC Director sent email stating that she would need to reschedule the meeting scheduled for April 9, 2008. She suggested that the meeting could occur between April 14 and April 18, 2008.
	April 4, 2008	Telephone	<ul style="list-style-type: none"> • KNOC left message for IRC Director to call back to reschedule meeting.



Participant	Date	Method	Discussion Points
Fort McMurray #468 First Nation (cont)	April 15, 2008	Telephone/Email	<ul style="list-style-type: none"> • KNOC left a voice mail for IRC Director to call back to reschedule meeting. • KNOC sent email to IRC Director suggesting that she call to reschedule meeting.
	April 17, 2008	Email	<ul style="list-style-type: none"> • IRC Director responded to KNOC's email and agreed to meeting on April 29, 2008. IRC Director suggested holding the meeting in the First Nations Board Room.
	April 23, 2008	Telephone/email	<ul style="list-style-type: none"> • KNOC called IRC Director to confirm details of meeting for April 29, 2008. IRC Director's voicemail was full and would not accept messages. • KNOC sent email to IRC Director to confirm details of meeting for April 29, 2008. Email mentioned that IRC Director's voicemail box is full and requests that she call KNOC.
	April 24, 2008	Telephone	<ul style="list-style-type: none"> • KNOC called IRC Director to determine if meeting could be scheduled for week of April 28, 2008. • IRC Director stated that she would not be available to meet during the week of April 28, 2008. She stated that the FMFN Chief and Council election was occurring on April 28, 2008 and depending on the results she would need to be available for the new council. • IRC Director asked what the purpose of the meeting would be. KNOC explained that they wanted to meet to discuss the consultation process. • IRC Director suggested that a meeting be tentatively arranged for May 7, 2008.
	April 29, 2008	Telephone	<ul style="list-style-type: none"> • KNOC called IRC Director to confirm meeting for May 7, 2008. IRC Director agreed to the meeting and stated that she had booked the First Nations board room for the meeting.
	April 30, 2008	Telephone	<ul style="list-style-type: none"> • KNOC left voice mail for IRC Director suggesting that the meeting scheduled for May 7, 2008 may need to be rescheduled.
	May 7, 2008	Meeting	<ul style="list-style-type: none"> • KNOC explained the history of the engagement and consultation activities that they undertook with the previous Director of the Fort McMurray First Nation IRC. • KNOC confirmed that the FMFN IRC received a copy of the KNOC application for approval to produce 10,000 bpd. • KNOC presented 'BlackGold SAGD Project Overview'.
	May 15, 2008	Telephone	<ul style="list-style-type: none"> • KNOC and IRC Director confirmed the meeting for June 4, 2008. • IRC Director committed to sending a draft agreement to KNOC.
	May 28, 2008	Email	<ul style="list-style-type: none"> • IRC Director sent email to KNOC which included a file with the 'IRC Associate Partnership Agreement'.
	June 4, 2008	Meeting	<ul style="list-style-type: none"> • KNOC presented the project description. • KNOC and the FMFN discussed the IRC agreement.
	June 6, 2008	Email	<ul style="list-style-type: none"> • KNOC sent email to IRC Director to follow-up on June 4, 2008 meeting. Email outlined several deliverables that were discussed in the meeting.
	June 9, 2008	Telephone	<ul style="list-style-type: none"> • KNOC called IRC Director to discuss status of deliverables from June 4, 2008 meeting and left voicemail.

Participant	Date	Method	Discussion Points
Fort McMurray #468 First Nation (cont)	June 12, 2008	Telephone	<ul style="list-style-type: none"> • KNOC called IRC Director and confirmed that she received email sent on June 6, 2008. • IRC Director confirmed that she had received the email, that she would send the requested material. She stated that it may take a few weeks to send the material.
	August 11, 2008	Telephone	<ul style="list-style-type: none"> • KNOC called and left a voicemail for IRC Director to return call.
	July 30, 2008	Telephone	<ul style="list-style-type: none"> • IRC staff called KNOC. IRC staff explained that the FMFN IRC is requesting funds for their Powwow day and stated that she will send a request for KNOC to pass on to KNOC. She also stated that they require a prompt response so that they can plan for food and activities. KNOC explained that they would consider the request and respond as soon as practical. • KNOC also explained that they were waiting for the documents which the IRC Director stated that she would provide to KNOC regarding the IRC and also an explanation of the fees that KNOC will be required to pay. • IRC staff explained that the IRC is working on drafting the IRC agreements and is hoping to have them prepared and distributed by August 15, 2008.
	August 13, 2008	Telephone	<ul style="list-style-type: none"> • IRC Director explained that the Fort McMurray First Nation has not yet drafted the KNOC IRC agreement and are still working on it. She explained that they are hoping to have them complete by September 23, 2008.
	September 5, 2008	Email	<ul style="list-style-type: none"> • IRC Director sent a request for funding an Elders Pow-Wow to Morley and Drumheller, Alberta
	September 23, 2008	Meeting	<ul style="list-style-type: none"> • This was FMFN IRC Funders Meeting. • The FMFN IRC made a presentation regarding overall FMFN IRC policy, structure, mission and proposed 2008/2009 budget. • FMFN IRC agreed that KNOC should join IRC as a non-producing member. • FMFN IRC agreed to set budget and fees for each funder and agreed to forward a draft agreement to KNOC.
	September 25, 2008	Email	<ul style="list-style-type: none"> • FMFN IRC Elders Coordinator sent email asking if Industry partners had any articles to submit to their quarterly newsletter.
	September 26, 2008	Telephone	<ul style="list-style-type: none"> • KNOC representative called FMFN IRC Elders Coordinator to discuss the notice about the Fort McMurray First Nation IRC newsletter. • FMFN IRC Elders Coordinator explained that this will be their second newsletter, they put one out in November 2007 and it is supposed to be released quarterly. • FMFN IRC Elders Coordinator explained that some companies did include some information in the previous newsletter but it is not required. • FMFN IRC Elders Coordinator explained that they will likely have too many articles and if a submission was made, did not want a large one. • KNOC representative asked FMFN IRC Elders Coordinator to send a copy of the November 2007 newsletter and also a copy of the newsletter to be sent in October 2008.

Participant	Date	Method	Discussion Points
Fort McMurray #468 First Nation (cont)	October 24, 2008	Telephone/Email	<ul style="list-style-type: none"> • KNOC representative phoned IRC Director to discuss winter and water programs. Left voicemail, requesting that the call be returned. • Sent IRC Director an email with a program description, and requested that she call to discuss the program.
	November 5, 2008	Telephone	<ul style="list-style-type: none"> • KNOC representative called FMFN IRC Director to discuss the status of the IRC agreement and explained that KNOC is anxious to receive this agreement, so that they can begin to fund the IRC and advance the engagement and consultation process. • FMFN IRC Director explained that the IRC agreement is still being revised by the IRC, the main funders and Chief and Council. She explained that it would be at least until November 21, 2008 until the agreement could be sent. • KNOC representative asked if KNOC and the IRC could begin to develop a consultation action plan. FMFN IRC Director replied that the IRC does not want to develop action plans until after the IRC agreement is finalized.
	November 20, 2008	Email	<ul style="list-style-type: none"> • KNOC representative sent email to IRC Director explaining that KNOC would be requesting approval from Alberta Sustainable Resource Development on the winter and water programs.
	January 13, 2009	Email	<ul style="list-style-type: none"> • FMFN IRC Director sent email stating that effective immediately the IRC Director for the Fort McMurray #468 First Nation is vacant until further notice.
	February 10, 2009	Telephone	<ul style="list-style-type: none"> • KNOC representative called Fort McMurray Elders Coordinator and left a voice mail requesting that she return the call.
	February 13, 2009	Telephone	<ul style="list-style-type: none"> • KNOC representative called Acting FMFN IRC Director. Voicemail was full and unable to leave a message.
	February 23, 2009	Telephone	<ul style="list-style-type: none"> • KNOC Representative called Acting FMFN IRC Director to discuss the status of the IRC Agreement, KNOC's IRC membership fees, and the development of an action plan. • Acting FMFN IRC Director explained that the IRC agreement is still being finalized by the Chief and Council and still could not be provided to KNOC until it was approved by Chief and Council. • Acting FMFN IRC Director explained that the 2009 IRC membership fees will be standardized and each full partner will pay the same as other full partners and each associate partner will pay the same as all other associate partners. • KNOC representative provided a status update on the project.
	May 12, 2009	Telephone	<ul style="list-style-type: none"> • KNOC representative left a message for FMFN IRC Director to return his call.
	May 12, 2009	Email	<ul style="list-style-type: none"> • FMFN IRC representative sent a funding request on behalf of the FMFN. Funding request was for 4 Directions Unity Run, a fund raising event.
	October 15, 2009	Telephone	<ul style="list-style-type: none"> • KNOC representative called FMFN IRC Director cell phone. Voicemail was full and unable to accept new messages.

Participant	Date	Method	Discussion Points
Fort McMurray #468 First Nation (cont)	October 15, 2009	Email	<ul style="list-style-type: none"> • KNOC representative sent FMFN IRC Director an email. • Email explains that KNOC would like to develop a consultation plan with the with Fort McMurray First Nation. • Email requests that FMFN IRC Director call KNOC representative. • Email contains the Plain Language Summary and Project Summary Table for the BlackGold Expansion Project.
	October 22, 2009	Telephone	<ul style="list-style-type: none"> • KNOC representative called FMFN IRC to arrange a meeting to discuss the KNOC BlackGold Project. • FMFN IRC Director suggested that KNOC representative send her an email identifying three potential meeting dates in the first or second week of November. FMFN IRC Director would then confirm her availability and the meeting arrangements could be finalized.
	October 29, 2009	Email	<ul style="list-style-type: none"> • KNOC representative sent email to FMFN IRC Director. • Email stated that KNOC is available to meet on November 6, 2009 or any day between November 9, 2009 and November 13, 2009.
	November 11, 2009	Email	<ul style="list-style-type: none"> • KNOC Representative sent email to FMFN IRC Director. • Email explains that KNOC is willing to meet with FMFN IRC Director to describe their proposed project and develop a consultation plan with the Fort McMurray First Nation. • Email also contained the proposed Terms of Reference and Public notice.
	November 11, 2009	Email	<ul style="list-style-type: none"> • FMFN IRC Director sent email to KNOC representative. • Email contained a proposal from MSES for costs to review and comment upon the proposed Terms of Reference for the KNOC BlackGold Expansion Project.
	November 12, 2009	Email	<ul style="list-style-type: none"> • KNOC representative emailed FMFN IRC Director. • Email requested that FMFN IRC Director call KNOC representative to discuss the proposal to review the proposed Terms of Reference.
Heart Lake First Nation	September 12, 2007	Email	<ul style="list-style-type: none"> • Discussion about arranging a meeting for October 17, 2007.
	October 12, 2007	Email	<ul style="list-style-type: none"> • Correspondence received from HLFN Consultation Coordinator for funding from KNOC.
	October 17, 2007	Meeting	<ul style="list-style-type: none"> • KNOC presented project overview and provided maps showing the location of the lease. • HLFN expressed interest in business opportunities. • HLFN explained the traditional lifestyle and importance of wildlife, particularly moose, plants, water, and the built environment which allowed them to pursue those resources such as hunting lodges. • HLFN recommended KNOC attend meeting with other industry representatives on October 31, 2007.
	October 2007	Emails	<ul style="list-style-type: none"> • Follow up from meeting of October 17th.
	October 31, 2007	Meeting	<ul style="list-style-type: none"> • This meeting was organized by the HLFN and several industry representatives, including KNOC, attended. • HLFN described the consultation process that they would like to use for developments occurring within their traditional lands.

Participant	Date	Method	Discussion Points
Heart Lake First Nation (cont)	December 14, 2007	Telephone	<ul style="list-style-type: none"> HLFN Consultation Office called KNOC to determine whether KNOC would join consultation office.
	December 17, 2007	Telephone	<ul style="list-style-type: none"> KNOC agreed to join consultation office. HLFN agreed to email agreement to KNOC. HLFN Consultation Office agreed to review the OSE program immediately.
	December 19, 2007	Telephone	<ul style="list-style-type: none"> Discussion about the HLFNCO Consultation Model. Heart Lake Consultation Office provided a letter of Satisfactory Consultation addressed to the ERCB and AENV and also provided a Consultation Report dated December 17, 2007.
	March 4, 2008	Email	<ul style="list-style-type: none"> HLFNCO sent email inviting KNOC to the HLFN Industry Meeting on March 12, 2008.
	March 11, 2008	Email	<ul style="list-style-type: none"> KNOC replied to HLFNCO that KNOC would attend the Industry Meeting.
	March 12, 2008	Meeting	<ul style="list-style-type: none"> The meeting was organized by the HLFN Consultation Office to update their industry partners about the status of the HLFN Consultation Office and the priorities of the HLFN and its members.
	April 9, 2008	Email	<ul style="list-style-type: none"> KNOC sent email to HLFNCO. KNOC requested information on the Chief to Chief Meetings requested by the HLFNCO, including date and time of the meeting, anticipated attendees and agenda.
	April 15, 2008	Telephone/email	<ul style="list-style-type: none"> KNOC sent email to HLFNCO. Forwarded email that was previously sent, and explained that the HLFNCO had not yet replied. KNOC left a voice mail for HLFNCO to call him. Called to discuss the Phase 1 application and go forward approach.
	April 28, 2008	Email	<ul style="list-style-type: none"> HLFNCO sent email that suggested that the HLFNCO wanted to hold a technical level meeting with KNOC and that the meeting occur in Calgary on May 5 to May 7, 2008, Suggested that the meeting address: <ul style="list-style-type: none"> – capacity for HLFN Consultation Office; – the KNOC environmental application; – traditional use study capacity/need; – community priorities; – Consultation Plan 2008/2009; and – Next steps – Chief to Chief meeting.
May 2, 2008	Telephone/email	<ul style="list-style-type: none"> KNOC confirmed that they are willing to meet with the HLFNCO and would like to do so on May 5, 2008. HLFNCO confirmed that they were available and would attend the meeting. The HLFNCO explained that they have not dealt with environmental assessment applications prior to KNOC's submission and wanted to discuss the process with KNOC. HLFNCO explained that they were glad that KNOC did not include information from the traditional knowledge (TK) report into the environmental assessment application because some of that information is confidential. HLFNCO did recognize that KNOC did acknowledge the TK that was provided by the HLFN Office and that was acceptable. 	

Participant	Date	Method	Discussion Points
Heart Lake First Nation (cont)	May 5, 2008	Telephone	<ul style="list-style-type: none"> • HLFNCO called KNOC to determine if the meeting scheduled for May 5, 2008 could be rescheduled and suggested that it could occur on May 6 or May 7, 2008. • KNOC suggested that due to conflicts the meeting would need to be rescheduled.
	June 9, 2008	Telephone	<ul style="list-style-type: none"> • KNOC called HLFNCO to discuss the status of the Phase 1 invoice and the go forward approach to consultation. • HLFNCO committed to sending a revised invoice. • HLFNCO stated that Chief and Council and the Consultation Office are trying to determine an appropriate consultation approach for different developers and they will respond to KNOC when that process is defined. • HLFNCO explained that the HLFN is satisfied with the consultation efforts of KNOC to date.
	June 12, 2008	Email	<ul style="list-style-type: none"> • HLFNCO sent email to KNOC. The email: <ul style="list-style-type: none"> – contained an approved version of the recreation program and cultural program and budgets; – invited KNOC to participate in the HLFN Treaty Days and Pow Wow Golf Tournaments on June 20, 2008 and July 4, 2008; and – suggested that the HLFNCO would like to meet with KNOC during the week of June 24, 2008 on the HLFN reserve.
	June 20, 2008	Email	<ul style="list-style-type: none"> • KNOC responded to the June 12, 2008 email from HLFNCO. KNOC expressed regret that they would not be able to attend the HLFN golf tournaments and suggested that the proposed meeting would need to be rescheduled.
	July 16, 2008	Telephone	<ul style="list-style-type: none"> • KNOC called HLFNCO to discuss rescheduling the meetings which the HLFN had proposed occur during the week of June 24, 2008. Left message on voicemail.
	July 18, 2008	Telephone	<ul style="list-style-type: none"> • KNOC called HLFNCO to discuss rescheduling the meetings which the HLFN had proposed occur during the week of June, 2008. Left message on voicemail.
	July 23, 2008	Telephone	<ul style="list-style-type: none"> • HLFNCO stated that the Heart Lake First Nation Consultation Office would like to arrange a meeting with KNOC and suggested a July 28, 2008 meeting in Edmonton.
	July 24, 2008	Telephone	<ul style="list-style-type: none"> • KNOC left a voice mail for HLFNCO, confirming that KNOC could attend a meeting on July 28, 2008 in Edmonton.
	July 25, 2008	Telephone/email	<ul style="list-style-type: none"> • HLFNCO emailed KNOC with recommendations on how to proceed with consultation. The email included three recommendations including a request for KNOC to fund a Traditional Land Use Study, joining the Consultation office, and contributing to Heart Lake First Nation Community Priorities.

Participant	Date	Method	Discussion Points
Heart Lake First Nation (cont)	July 28, 2008	Meeting	<ul style="list-style-type: none"> The Heart Lake First Nation Consultation Office and KNOC met to discuss the processes required to advance the consultation program. Discussion topics included: <ul style="list-style-type: none"> – review of the Phase 1 application; – potential funding from KNOC for the Heart Lake First Nation Traditional Land Use Study; – KNOC funding to the Heart Lake First Nation Consultation Office for capacity funding; – funding for Heart Lake First Nation community priorities; and – an invoice for 2008 OSE program and Phase 1 review of the application.
	August 10, 2008	Email	<ul style="list-style-type: none"> HLFNCO emailed KNOC information which he had committed to providing. The emailed information included: <ul style="list-style-type: none"> – Heart Lake First Nation Traditional Land Use Study Proposal 2008; – Heart Lake First Nation Consultation Office Capacity Commitments; – KNOC – Heart Lake First Nation – Heart Lake First Nation Consultation Office Capacity Agreement; and – an invitation to attend the a meeting to update the Heart Lake First Nation Consultation Office and Elders about the Winter Program 2008/2009 plans on September 3, 2008.
	August 13, 2008	Telephone	<ul style="list-style-type: none"> KNOC called HLFNCO representative to inform him that KNOC has approved the invoice from the Heart Lake First Nation Consultation Office for the 2007/2008 Winter Works Program. HLFNCO mentioned that the HLFNCO Capacity Agreement for 2007-2008, which they had sent on August 10, 2008, was being revised and explained that the Chief of the Heart Lake First Nation and the Director of the HLFNCO thought that the agreement was too long and complicated. They have revised it, so that it will be a much simpler document to review. The HLFNCO stated that he would send the revised document during the week of August 25, 2008. KNOC informed the HLFNCO that KNOC would attend the proposed meeting on September 3, 2008 to discuss their 2008/2009 Winter Works Program. Sent email confirming that KNOC would attend September 3, 2008 meeting to discuss 2008/2009 Winter Works Program. Email also confirmed KNOC understands that Heart Lake First Nation Consultation Office will send revised agreement during week of August 25, 2008.

Participant	Date	Method	Discussion Points
Heart Lake First Nation (cont)	August 18, 2008	Telephone	<ul style="list-style-type: none"> • KNOC called the HLFNCO to determine what types of information and level of detail, the Heart Lake First Nation would like presented to the Elders during the September 3, 2008 meeting. • The HLFNCO explained that KNOC should present an overview of their OSE program and explained that the Elders would be particularly interested in knowing about the locations of the proposed work. The HLFNCO suggested speaking about the type of work that would be undertaken, the locations of the work, and the timing of the work. The HLFNCO also explained that the presentation should be on PowerPoint, and that it would be useful to have large paper maps of the locations of the proposed work. • The HLFNCO also stated that they were going to send KNOC a revised agreement to join the Heart Lake First Nation Consultation Office, and anticipated that he would send it later in the day. • The HLFNCO also asked about the status of invoice for the previous years work. KNOC explained that they had accepted the invoice and would pay it promptly.
	September 3, 2008	Meeting	<ul style="list-style-type: none"> • The HLFNCO invited KNOC and several other companies to attend an Elders Meeting and present their 2008/2009 OSE Program. • The meeting was preceded by a lunch hosted by the Heart Lake First Nation. • The HLFNCO introduced the meeting explaining that they are trying to educate the Elders about OSE Programs, and spent the morning in sessions to help them understand the purpose of the projects and how they work. • The HLFNCO then facilitated the Elders sessions. Each company presented their OSE Program separately. • KNOC made a presentation describing the project and their 2008/2009 OSE Program. • There were a few questions and concerns from the Elders: <ul style="list-style-type: none"> – the Elders were particularly concerned about water and questioned how KNOC could conduct their OSE Program without disturbing surface waters. KNOC explained that there would be a set-back from the waters including Christina Lake and would not operate within 400 m of the lake; – the Elders asked what would happen if KNOC encountered gas while drilling for oil. KNOC explained that they were unlikely to hit gas in this area. It was also explained that if gas was encountered the ERCB would regulate how it needed to be dealt with; and – the Elders expressed their opinion that it was important to protect the environment. KNOC explained that they want to complete their program and will work to minimize environmental damage. KNOC explained that they have not developed their procurement and employment policy, but has committed to providing local and Aboriginal people and businesses opportunities. • The Elders asked where the oil which is produced from the project would end up and if it would be going to Korea. KNOC replied that the oil would be sold within the North American market.
	September 19, 2008	Email	<ul style="list-style-type: none"> • Heart Lake First Nation sent consultation agreement.
	October 17, 2008	Email	<ul style="list-style-type: none"> • Heart Lake First Nation Consultation Office Regulatory Affairs Director sent email requesting funds to support a Heart Lake First Nation Elders retreat scheduled for October 21, 2008.

Participant	Date	Method	Discussion Points
Heart Lake First Nation (cont)	October 30, 2008	Email	<ul style="list-style-type: none"> Heart Lake First Nation Consultation Office Regulatory Affairs Director to KNOC email and revised Consultation Office Support Letter Agreement. Heart Lake First Nation Consultation Office Regulatory Affairs Director stated that the changes were acceptable and made one minor revision. Heart Lake First Nation Consultation Office Regulatory Affairs Director stated that Heart Lake Consultation Office Director would send signed letter to KNOC. Heart Lake First Nation Consultation Office Regulatory Affairs Director also stated that he would send letter describing 2008/2009 OSE winter program review, once the letter was signed by the Chief.
	November 5, 2008	Telephone	<ul style="list-style-type: none"> Heart Lake First Nation Consultation Office Regulatory Affairs Director called KNOC representative to explain that he would be faxing a copy of the signed Consultation Office Support Agreement, as well as a sign off letter for the 2008/2009 OSE Program. KNOC representative asked if there were any additional steps required prior to the end of the year. Heart Lake First Nation Consultation Office Regulatory Affairs Director stated that he did not think any additional consultation activities would be required. Heart Lake First Nation Consultation Office Regulatory Affairs Director did explain that the Heart Lake First Nation was preparing their community priorities in early 2009 and would request that KNOC contribute to those in 2009.
	November 6, 2008	Faxed letters	<ul style="list-style-type: none"> Heart Lake First Nation Consultation Office Regulatory Affairs Director sent fax that contained: <ul style="list-style-type: none"> copy of the Heart Lake Consultation Office Support Letter Agreement signed by Chief of the Heart Lake First Nation; and copy of a letter sent to Alberta Sustainable Resource Development stating that the Heart Lake First Nation has no site specific concerns related to winter resource development programs in the BlackGold SAGD project area.
	November 7, 2008	Email	<ul style="list-style-type: none"> KNOC representative sent email with signed HLFN Consultation Agreement and stated that the original signed agreement would follow in the mail. KNOC representative also stated that invoice for last quarter of 2008 would be paid during the week November 10, 2008.
	November 28, 2008	Email	<ul style="list-style-type: none"> Heart Lake First Nation Consultation Office Regulatory Affairs Director sent invitation to attend a meeting of the Heart Lake First Nation Consultation Office on December 10, 2008.
	December 2, 2008	Email	<ul style="list-style-type: none"> Heart Lake First Nation Consultation Office sent invoice to KNOC requesting payment for consultation fees, as per consultation agreement.
	December 3, 2008	Email	<ul style="list-style-type: none"> KNOC representative replied to Heart Lake First Nation Consultation Office Regulatory Affairs Director email of November 28 and responded that KNOC representatives would attend the meeting.
	December 4, 2008	Email	<ul style="list-style-type: none"> KNOC representative responded to HLFNCO email of December 2, 2008. Email explained that KNOC will pay the Heart Lake First Nation Consultation Office Invoice and that payment should be received by the consultation office during the week of December 8, 2008.

Participant	Date	Method	Discussion Points
Heart Lake First Nation (cont)	December 10, 2008	Meeting	<ul style="list-style-type: none"> Heart Lake First Nation Consultation Office Annual Review and Community Priorities Presentation to Industry Partners: <ul style="list-style-type: none"> purpose of the meeting was for the Heart Lake First Nation to update their industry partners on the activities and budget of the Heart Lake First Nation Consultation Office.
	January 8, 2009	Email	<ul style="list-style-type: none"> Heart Lake First Nation Consultation Office Regulatory Affairs Director sent email about a meeting with the Chief to discuss plans for the Heart Lake Community Complex and to receive commitments from companies to provide funds for the centre.
	January 9, 2009	Telephone	<ul style="list-style-type: none"> KNOC representative contacted Heart Lake First Nation Consultation Office Regulatory Affairs Director to explain that KNOC would not be able to contribute funds to the community centre and explained that KNOC does not have any production from their project. Heart Lake First Nation Consultation Office Regulatory Affairs Director stated that he understood why KNOC could not contribute funds to community centre and did not think that it would be a concern for the Chief or Community. KNOC representative stated that KNOC did want to work with the Heart Lake First Nation to collect traditional knowledge and traditional land use information. Heart Lake First Nation Consultation Office Regulatory Affairs Director asked KNOC representative to contact him during the week of January 12, 2009 to discuss this matter further.
	March 3, 2009	Telephone	<ul style="list-style-type: none"> The purpose of the conversation was to discuss a process for completing a traditional knowledge study with the Heart Lake First Nation on the KNOC lease. Heart Lake First Nation Consultation Office Regulatory Affairs Director discussed the process that the Heart Lake First Nation would like to use for the traditional knowledge study. He explained that they would like to complete two site visits, one with Elders, the second with an environmental monitor and an Elder. He also explained that the Heart Lake First Nation would prepare a report based on the TK and any issues and concerns that were raised by the Elder and monitor. Heart Lake First Nation Consultation Office Regulatory Affairs Director agreed to provide KNOC with a proposal to complete the traditional knowledge study.
	March 11, 2009	Telephone	<ul style="list-style-type: none"> KNOC representative called HLFN representative to discuss the status of the proposal to complete a traditional land use study, which HLFN representative had committed to providing to KNOC. Left a voicemail requesting that HLFN representative return the call.
	March 13, 2009	Telephone	<ul style="list-style-type: none"> KNOC representative called HLFN representative to discuss the status of the proposal to complete a traditional land use study, which HLFN representative had committed to providing to KNOC. HLFN representative stated that he had sent the proposal, via email. KNOC representative explained that he had not yet received it. HLFN representative committed to resending it on March 13, 2009.

Participant	Date	Method	Discussion Points
Heart Lake First Nation (cont)	March 25, 2009	Telephone	<ul style="list-style-type: none"> • KNOC representative and HLFN representative discussed the process for completing a site specific TK study for the KNOC lease. • KNOC representative and HLFN representative also discussed funding for a HLFN TK study for their entire traditional territory. • HLFN representative requested the KNOC shapefiles of the lease and project footprint. • HLFN representative explained that the Heart Lake First Nation is very interested in securing business opportunities from the KNOC project and that the Chief would like to meet with KNOC to discuss this further.
	April 6, 2009	Telephone	<ul style="list-style-type: none"> • KNOC representative called HLFN representative to discuss the process for completing the TK study site visit. • HLFN representative explained that the site visit was no longer required. He explained that the Elders viewed the site from the BP road and were satisfied that they understood the lease conditions and did not need to travel on the lease. • HLFN representative explained that the Elders would meet on May 20, 2009 to discuss the project and their traditional land use in the area. HLFN representative explained that it would not be necessary for KNOC to attend the meeting. • HLFN representative explained that KNOC would receive a TK report in August 2009 and then a follow-up meeting to address any issues and concerns could be arranged.
	May 22, 2009	Email	<ul style="list-style-type: none"> • HLFN representative sent invoice for Consultation Capacity for the Heart Lake First Nation Consultation Office for Q1 2009/2010.
	May 27, 2009	Email	<ul style="list-style-type: none"> • HLFN representative sent email. • Email contained an attached calendar of Heart Lake Events from 09/06/01 to 09/08/31.
	June 4, 2009	Email	<ul style="list-style-type: none"> • HLFN representative mentioned that he would follow-up with progress on the company specific traditional land use study for the BlackGold Project, and the related invoicing. • HLFN representative stated that a plan needs to be developed to address the community priorities requests and economic development relationship. He suggested that a meeting occur in the near future.
	June 30, 2009	Telephone	<ul style="list-style-type: none"> • KNOC representative called HLFN representative and indicated that KNOC would like to set up a meeting to discuss benefits agreements. • HLFN representative and KNOC representative agreed that they would speak about it further on July 6, 2009.
	July 2, 2009	Email	<ul style="list-style-type: none"> • HLFNCO Director sent email inviting KNOC and other companies to participate in Heart Lake First Nation Treaty Days and Annual Pow Wow July 10, 2009, July 11, 2009 and July 12, 2009.

Participant	Date	Method	Discussion Points
Heart Lake First Nation (cont)	July 6, 2009	Telephone	<ul style="list-style-type: none"> • KNOC representative explained KNOC may not be able to attend the Heart Lake Treaty Days and Pow Wow. • KNOC representative and HLFN representative discussed potential dates for a meeting to discuss benefits agreements. • KNOC representative and HLFN representative discussed the structure of a possible agreement. • HLFN representative agreed to provide a profile on Heart Lake First Nation businesses and a business profile and package to help guide the economic development and training negotiations.
	July 6, 2009	Email	<ul style="list-style-type: none"> • HLFN representative sent email containing Heart Lake First Nation Business Package.
	August 13, 2009	Telephone	<ul style="list-style-type: none"> • KNOC representative left a voicemail for HLFN representative requesting that he return the call.
	August 21, 2009	Telephone	<ul style="list-style-type: none"> • KNOC representative left a voicemail for HLFN representative and requested that HLFNCO representative return the call. • KNOC representative explained that KNOC wanted to discuss the traditional knowledge study and advance the benefits discussions.
	August 25, 2009	Telephone	<ul style="list-style-type: none"> • HLFN representative returned KNOC representatives call from August 21, 2009. • KNOC representative explained that the ERCB would be sending a letter to Heart Lake First Nation and other Aboriginal communities to ask if they had any issues and concerns with the project. HLFN representative replied that he thought they had received the letter. He also explained that generally the Heart Lake First Nation does not object to developments and is unlikely to do so for the BlackGold Expansion Project. • HLFN representative explained that the TK study for the BlackGold lease is nearly complete and that he should be able to send it to KNOC in the second week of September 2009. • HLFN representative explained that the comprehensive traditional knowledge study covering the traditional territory of the Heart Lake First Nation would likely be complete in October 2009. • HLFN representative stated that he would send KNOC representative an email confirming the discussion, and an invoice for the TK study on August 25, 2009.
	September 4, 2009	Email	<ul style="list-style-type: none"> • HLFN representative sent email containing Heart Lake First Nation Traditional Land Use Study Support Letter Agreement for KNOC to sign.
	September 4, 2009	Email	<ul style="list-style-type: none"> • HLFN representative sent email containing Heart Lake First Nation Traditional Land Use Study proposal from 2008.
	September 4, 2009	Email	<ul style="list-style-type: none"> • HLFN representative sent email containing third quarter invoice for Heart Lake First Nation Consultation Office.

Participant	Date	Method	Discussion Points
Heart Lake First Nation (cont)	September 8, 2009	Telephone	<ul style="list-style-type: none"> • KNOC representative called HLFN representative to discuss TK study. • HLFN representative confirmed that the Heart Lake First Nation Consultation Office is working on the TK study for KNOC. HLFN representative explained that a study specific to the KNOC lease will be provided to KNOC. • KNOC representative asked when the study would be completed. HLFN representative replied that he would inquire with the study author and respond to KNOC. • KNOC representative also asked about the fees for the overall TK study and the fees for the study specific to KNOC and how the two related. HLFN representative stated that the fees for the comprehensive study were not covering the field work. He suggested that those additional fees would be for field work. He also stated that he would speak with HLFNCO Director to confirm if the additional fees would be collected. • KNOC representative also stated that the ERCB sent out letters to the Aboriginal communities potentially affected by the KNOC project. HLFN representative confirmed that he had received the letter.
	October 6, 2009	Telephone	<ul style="list-style-type: none"> • KNOC representative called HLFN representative to discuss the status of the Heart Lake First Nation Traditional Knowledge Study. • KNOC representative explained that KNOC was preparing an EIA and wanted to have the traditional knowledge as soon as possible, so that it could be fully integrated into the assessment. • HLFN representative explained that the Heart Lake First Nation Consultation Office was still developing their processes for sharing TK with developers. HLFN representative stated that he understood the urgency and would respond to KNOC representative in the near future. • KNOC representative also explained that Alberta Environment had released the proposed Terms of Reference for the expansion project. KNOC representative explained that the proposed terms of reference needed to be posted in the Heart Lake Community Centre. HLFN representative offered to post the Terms of Reference in the Heart Lake Community Centre.
	October 6, 2009	Email	<ul style="list-style-type: none"> • KNOC representative sent HLFN representative the proposed Terms of Reference and Public Notice for the KNOC BlackGold Expansion Project.
	October 8, 2009	Email	<ul style="list-style-type: none"> • HLFN representative sent an email explaining that the Heart Lake First Nation does want to complete a Traditional Land Use report for KNOC promptly. • The email also explained that the Heart Lake First Nation had some concern about the confidentiality of the report. • Email also asked if KNOC was planning an OSE Program for winter 2009-2010 and suggested that a consultation process will need to be developed if such an activity is planned.
	October 9, 2009	Email	<ul style="list-style-type: none"> • KNOC representative replied to HLFN representative email. • KNOC representative explained that KNOC understands the Heart Lake First Nation is developing a process to complete TK studies and also explained that KNOC understands the Heart Lake First Nations concern about confidentiality and wants to work with the Heart Lake First Nation to document the data in a respectful manner. • KNOC representative stated that he will speak with HLFN representative about the upcoming OSE program and develop a consultation process.

Participant	Date	Method	Discussion Points
Heart Lake First Nation (cont)	October 13, 2009	Email	<ul style="list-style-type: none"> • HLFN representative sent email to KNOC representatives. • HLFN representative sent TLU/TEK work plan, letter agreement and schedule for proposed TLU/TEK study.
	October 14, 2009	Telephone	<ul style="list-style-type: none"> • KNOC representative called HLFN representative to discuss the TLU-TEK proposal that was submitted to KNOC. • KNOC representative explained that KNOC was prepared to accept the proposal, but hoped that the schedule could be improved and the report to KNOC expedited. KNOC representative also explained that it was important that KNOC be able to report some of the results of the TK study to the regulators and therefore had a bit of concern about the confidentiality requirements suggested by the Heart Lake First Nation. • HLFN representative stated that much of the TLU-TEK report is already completed and that the HLFN should be able to expedite the report. HLFN representative stated that he would make best efforts to complete the report by October 23, 2009. • HLFN representative stated that one concern of the HLFN is that inappropriate information from the TK study may make it into public documents. HLFN representative stated that other proponents have included the names of individual harvesters, and other data that the HLFN did not want released. HLFN representative stated that is one reason they wanted to take more time to review the reports to ensure that they do not provide proponents with information they do not want in the public domain. • KNOC representative explained that if the HLFN provided TLU-TEK information to KNOC, KNOC would allow the HLFN to review the information prior to it being filed with the regulators. HLFN representative agreed that he should be able to provide the report by October 23, 2009 with that agreement in place.
	October 15, 2009	Email	<ul style="list-style-type: none"> • KNOC representative sent HLFN representative an email. • Email contained the KNOC BlackGold Expansion Project Plain language summary and Project Summary Table. • Email also explained that KNOC looks forward to working with the HLFNCO to develop a consultation plan for the expansion project.
	October 16, 2009	Email	<ul style="list-style-type: none"> • HLFN representative sent email stating that he was working on the HLFN TK study for KNOC and it will contain a lot of information.
	October 20, 2009	Email	<ul style="list-style-type: none"> • HLFN representative sent email to KNOC representative. • Email contained invoice for Heart Lake Traditional Knowledge Study.
	October 20, 2009	Email	<ul style="list-style-type: none"> • KNOC representative responded to HLFN representatives email regarding HLFNCO invoice for the traditional knowledge study. • Email also contained an attachment with a signed Traditional knowledge study support agreement signed by KNOC representative. Email requested that Heart Lake First Nation representative sign the agreement and provide a copy to KNOC for their records.
	October 21, 2009	Email	<ul style="list-style-type: none"> • HLFN sent email acknowledging that she received email from KNOC representative and would forward a copy of the signed Traditional Land Use Support Agreement to KNOC for their records.

Participant	Date	Method	Discussion Points
Heart Lake First Nation (cont)	October 23, 2009	Email	<ul style="list-style-type: none"> • HLFN representative sent email. • Email contains an update on the Heart Lake First Nation Consultation Office activities. • Email also asked about availability of consultation office contributors for a meeting on November 4, 2009.
	October 23, 2009	Email	<ul style="list-style-type: none"> • KNOC representative responded to HLFN representative email. • KNOC representative explained that KNOC had a conflict on November 4, 2009. • Email stated that KNOC would prefer if the meeting could be rescheduled and would make best efforts to attend the meeting.
	October 28, 2009	Telephone	<ul style="list-style-type: none"> • HLFN representative called KNOC representative to explain that the HLFNCO is actively working on the traditional knowledge and traditional land use study, which will contain a lot of information. • HLFN representative indicated that he would send a revised schedule for the study to KNOC representative, and anticipated that the study would be completed in late November 2009. • KNOC representative thanked HLFN representative for his diligence and stated that if KNOC did not get the study report until late November 2009, it would be difficult to incorporate the information into the environmental assessment report, but that KNOC would do their best to do so. • HLFN representative also stated that he understood KNOC could not make the meeting on November 4, 2009 and would provide KNOC with information and minutes from the meeting.
	October 28, 2009	Email	<ul style="list-style-type: none"> • HLFN representative sent email, which was also sent to several developers. • Email contained an invitation to attend a meeting on November 4, 2009 in Heart Lake. The purpose of the meeting is to update all funders to the Heart Lake First Nation Consultation Office on the increased needs and expectations of the community. • Email also confirmed that those unable to attend the meeting would be sent materials and a follow-up phone call.
	November 2, 2009	Email	<ul style="list-style-type: none"> • HLFN representative sent email. • Email stated that the proposed meeting for November 4, 2009 would be postponed due to illness. An alternative meeting date was suggested for November 18, 2009.
	November 3, 2009	Email	<ul style="list-style-type: none"> • KNOC representative sent email. • Email explained that KNOC did have a meeting conflict on November 18, 2009, hoped that the meeting could be rescheduled, but would also try to attend if the meeting did occur.
	November 16, 2009	Email	<ul style="list-style-type: none"> • HLFNCO sent email. • Email proposed new date and time for HLFNCO Industry meeting. It was stated that the meeting would occur on November 26, 2009 in Calgary. • Email explained that the purpose of the meet will be for the HLFNCO to provide an annual update on the work of the HLFNCO, and determine a plan to ensure increased capacity needs of the office can be met.

Participant	Date	Method	Discussion Points
Heart Lake First Nation (cont)	November 17, 2009	Email	<ul style="list-style-type: none"> HLFNCO representative sent email explaining that he had drafted a version of the Heart Lake First Nation Traditional Land Use Study for KNOC. HLFNCO explained that the report was circulated to an internal team, and after review, additional changes would be required. HLFNCO representative stated that he would provide the report to KNOC as soon as possible.
	November 18, 2009	Email	<ul style="list-style-type: none"> HLFNCO representative provided a status update regarding the Heart Lake First Nation Traditional Land Use Study for KNOC.
	November 20, 2009	Email	<ul style="list-style-type: none"> HLFNCO provided the Draft Heart Lake First Nation Traditional Land Use Report for the KNOC Initial BlackGold Project and BlackGold Expansion Project.
	November 24, 2009	Email	<ul style="list-style-type: none"> HLFNCO representative sent a number of attachments related to the HLFNCO budget and funding commitments.
	November 26, 2009	Meeting	<ul style="list-style-type: none"> HLFNCO meet with industry partners, including KNOC, to provide an update on the activities of the HLFNCO, and to discuss the budget of the HLFNCO.
	November 30, 2009	Email	<ul style="list-style-type: none"> HLFNCO representative sent email with requests for funding of the HLFN Community Christmas Party for 2009 and the HLFN Annual Winterfest to be held in March 2010.
Conklin Métis Local #193	November 16, 2007	Telephone	<ul style="list-style-type: none"> KNOC called to determine if a meeting could be arranged with the Conklin Métis Local #193 on November 20, 2007. President of the Conklin Métis Local #193 requested KNOC contact CRDAC Advisor (consultant to Conklin Métis Local #193) to determine if a meeting could be arranged.
	November 16, 2007	Telephone	<ul style="list-style-type: none"> CRDAC Advisor and KNOC agreed to hold a meeting with Conklin Métis Local #193 Board and KNOC representatives on November 20, 2007.
	November 20, 2007	Meeting	<ul style="list-style-type: none"> KNOC presented project overview. Conklin Métis Local #193 explained the need to consult with the Conklin Métis. Conklin Métis Local #193 agreed to provide KNOC with a consultation plan. Conklin Métis Local #193 expressed importance of building community capacity. Conklin Métis Local #193 explained that they are completing a TK study and suggested that KNOC fund the study rather than initiate a separate study.
	January 14, 2008	Telephone	<ul style="list-style-type: none"> Conklin Métis Local #193 consultant committed to providing KNOC with an action plan and work plan which KNOC and the Conklin Métis Local #193 can use to develop a consultation plan.
	March 18, 2008	Telephone	<ul style="list-style-type: none"> KNOC called Conklin Métis Local #193 consultant and left a message.

Participant	Date	Method	Discussion Points
Conklin Métis Local #193 (cont)	March 19, 2008	Telephone	<ul style="list-style-type: none"> • KNOC called the President of the Conklin Métis Local #193 to ask about the action plan that they had committed to sending to KNOC. • The President of the Conklin Métis Local #193 replied that they had sent action plans to several other companies and still had it on their agenda to send on to KNOC. They just had not gotten to it yet. • KNOC explained that they were aware that the Conklin Métis Local #193 and the Conklin Community Association were coordinating their consultation efforts and asked if that coordination would be part of the action plan. The Conklin Métis Local #193 confirmed that it would be. • KNOC explained that they had submitted an application for approval to produce 10,000 bpd and asked if the Conklin Métis Local #193 would like a copy of the application. The Conklin Métis Local #193 requested that the application be sent to them.
	April 3, 2008	Telephone	<ul style="list-style-type: none"> • KNOC called CRDAC Advisor to discuss the consultation process that KNOC can use for the project. • Conklin Métis Local #193 consultant apologized for not responding yet and suggested that she has been very busy. She said that she would send the action plan by April 11, 2008 and perhaps as soon as April 6, 2008. • Conklin Métis Local #193 consultant explained that the Conklin Community Association and Conklin Métis Local #193 are working on developing a single approach to consultation. • Conklin Métis Local #193 consultant explained that the approach will be issues based rather than regulatory based. • Conklin Métis Local #193 consultant stated that there will be a Trade Show in Conklin on May 14, 2008 and suggested that KNOC attend. She said that further information will be provided in the week of May 11, 2008. • Conklin Métis Local #193 consultant requested that a copy of the Phase 1 application be sent to her.
	April 9, 2008	Telephone	<ul style="list-style-type: none"> • KNOC called CRDAC Advisors she had requested to follow-up on previous discussions regarding the Action Plans. • Conklin Métis Local #193 consultant explained that she is working with the Conklin Community Association and Conklin Métis Local #193 to produce the action plans. She explained that the action plans are in draft and that the community members are commenting on them. She explained that the Action Plans will not be available until the end of April 2008. • CRDAC Advisor explained that KNOC and other companies will be invited to a Trade Show in Conklin that will occur on May 14, 2008. She said that the invitation will be sent to KNOC on May 11, 2008.
	April 15, 2008	Telephone	<ul style="list-style-type: none"> • KNOC called Conklin Métis Local #193 consultant to maintain contact and to inform her that they had not received email about the Trade Show which Conklin Métis Local #193 consultant had committed to sending April 11, 2008.
	May 6, 2008	Telephone/email	<ul style="list-style-type: none"> • KNOC called Conklin Métis Local #193 consultant regarding KNOC's participation in the Conklin Trade Show on May 14, 2008. • Conklin Métis Local #193 consultant requested that KNOC send her an email. • KNOC sent email to CRDAC Advisor to confirm that KNOC would participate in Conklin Trade Show.



Participant	Date	Method	Discussion Points
Conklin Métis Local #193 (cont)	May 14, 2008	Meeting	<ul style="list-style-type: none"> • KNOC participated in the Conklin Trade Show. • KNOC had a booth at the Trade Show. • No specific issues or concerns with the project were raised during the Trade Show.
	May 23, 2008	Meeting	<ul style="list-style-type: none"> • Meeting to discuss the Conklin Resource Development Advisory Committee.
	July 14, 2008	Telephone	<ul style="list-style-type: none"> • KNOC left a message for Conklin Métis Local #193 consultant to call KNOC to speak about Action Plans.
	July 16, 2008	Telephone	<ul style="list-style-type: none"> • KNOC left a message for Conklin Métis Local #193 consultant to call KNOC to speak about Action Plans. • Conklin Métis Local #193 consultant called KNOC and suggested that he call her on the morning of July 17, 2008.
	July 17, 2008	Telephone	<ul style="list-style-type: none"> • KNOC called Conklin Métis Local #193 consultant to discuss the drafting of an Action Plan. • Conklin Métis Local #193 consultant suggested that KNOC develop the action plan, send a draft to her and then discuss that draft with her on a conference call. • Conklin Métis Local #193 consultant confirmed that she had received KNOC's regulatory application for the project.
	July 22, 2008	Telephone/email	<ul style="list-style-type: none"> • As requested by Conklin Métis Local #193 consultant, KNOC sent a draft Action Plan, to her for review by the Conklin Métis Local #193. • KNOC called and left a message for Conklin Métis Local #193 consultant to return call.
	July 23, 2008	Telephone	<ul style="list-style-type: none"> • KNOC called and spoke with Conklin Métis Local #193 consultant. She confirmed that she had received email from July 22, 2008 and would review the Action Plan in the afternoon of July 23, 2008.
	July 24, 2008	Telephone	<ul style="list-style-type: none"> • KNOC called and spoke with Conklin Métis Local #193 consultant. She stated that she has not yet had an opportunity to review the Action Plan and will do so on July 25, 2008.
	July 30, 2008	Telephone	<ul style="list-style-type: none"> • KNOC called and left a voice mail for Conklin Métis Local #193 consultant to return the call.
	July 31, 2008	Telephone	<ul style="list-style-type: none"> • KNOC called and left a voice mail for Conklin Métis Local #193 consultant to return the call. • Conklin Métis Local #193 consultant called KNOC to explain that she is still dealing with the results of a thunderstorm which has affected her computer and telephone lines, as well as a personal matter, and as a result has not yet reviewed the draft action plan submitted by KNOC. • Conklin Métis Local #193 consultant explained that she will review the application on August 1, 2008.
	August 5, 2008	Telephone	<ul style="list-style-type: none"> • KNOC called Conklin Métis Local #193 consultant to discuss the Action Plan. • Conklin Métis Local #193 consultant suggested that she and KNOC schedule a telephone meeting for August 6, 2008. KNOC agreed. • Conklin Métis Local #193 consultant explained that it should be possible to finalize the Action Plan, to the point that it could be sent to Conklin Métis Local #193 and KNOC for approval in the meeting. • Conklin Métis Local #193 consultant also stated that the Conklin Métis 193 will be looking for sponsorship for their TK study.

Participant	Date	Method	Discussion Points
Conklin Métis Local #193 (cont)	August 6, 2008	Telephone	<ul style="list-style-type: none"> • Conklin Métis Local #193 consultant and KNOC reviewed the Draft Action Plan submitted by KNOC. CRDAC Advisor suggested several revisions to the draft Action Plan submitted by KNOC and sent a revised document based on the discussion. • It was agreed that Conklin Métis Local #193 consultant and KNOC would speak about the revised Action Plan on August 7, 2008.
	August 7, 2008	Telephone/email	<ul style="list-style-type: none"> • Conklin Métis Local #193 consultant sent a copy of the Conklin Métis TLUS Proposal revised in August 2008. • Conklin Métis Local #193 consultant and KNOC spoke about revisions to the Draft Action Plan.
	August 11, 2008	Telephone/email	<ul style="list-style-type: none"> • KNOC called Conklin Métis Local #193 consultant to discuss the Draft Action Plan. KNOC explained that they had reviewed the Action Plan and was concerned only with the schedule. Explained that KNOC had hoped to receive a letter of support from the Conklin Métis in September or October 2008 and wondered if the schedule could be adapted. • Conklin Métis Local #193 consultant explained that it would not be possible to adjust the schedule. She explained that she would send the Action Plan to the regulators once it was approved, and then if required would send regular letters updating the regulators as to the progress that was being made. • KNOC explained that other than the schedule there were only a few minor editorial changes made to the Action Plan and sent an email with revised draft Action Plan to Conklin Métis Local #193 consultant. Conklin Métis Local #193 consultant explained that she would be in Calgary from August 12, 2008 to August 13, 2008 and suggested that KNOC reps and her have lunch on August 12, 2008.
	August 13, 2008	Meeting	<ul style="list-style-type: none"> • KNOC meet with Conklin Métis Local #193 consultant to discuss the Conklin Métis Local #193 and KNOC Joint Action Plan. • Conklin Métis Local #193 consultant described the rationale behind the Action Plan. • Conklin Métis Local #193 consultant discussed the Conklin Resource Development Action Committee (CRDAC), its history, mandate and issues. • Conklin Métis Local #193 consultant asked which other Aboriginal communities KNOC was consulting with. KNOC provided her with the list of Aboriginal stakeholders that KNOC was consulting with. Conklin Métis Local #193 consultant expressed her thoughts that KNOC should only be consulting with the Conklin Métis Local #193 and Chipewyan Prairie Dene First Nation. She thought that they were the only Aboriginal stakeholders that would be directly and adversely affected. • Conklin Métis Local #193 consultant stated that she would send KNOC an email describing the rationale for the Action Plan to KNOC by end the end of August 13, 2008.
	August 14, 2008	Email	<ul style="list-style-type: none"> • Conklin Métis Local #193 consultant sent email describing rationale for Action Plan. • Email also explained rationale and purpose of traditional land use study.

Participant	Date	Method	Discussion Points
Conklin Métis Local #193 (cont)	August 18, 2008	Telephone/email	<ul style="list-style-type: none"> • KNOC representatives left Conklin Métis Local #193 consultant voicemails, on both her landline and cell phone, explaining that KNOC supports the Joint Conklin Métis Local #193 and KNOC Action Plan and would like Bonnie to present the Action Plan to the Conklin Métis Local #193 Board of Directors on August 20, 2008. • Sent Conklin Métis Local #193 consultant an email confirming that KNOC supports the draft Action Plan and would like her to present it to the Conklin Métis Local #193 Board of Directors.
	August 19, 2008	Telephone	<ul style="list-style-type: none"> • Conklin Métis Local #193 consultant called KNOC to verify that she received messages and email that KNOC had approved the draft Action Plan. • Conklin Métis Local #193 consultant explained that she was in Conklin and would be meeting with the Conklin Métis Local #193 Board of Directors on August 19 and August 20, 2008 and would present the draft Action Plan to them for approval. • Conklin Métis Local #193 consultant stated that she would call KNOC on August 22, 2008 to inform him of the decision made by the Conklin Métis Local #193 Board of Directors.
	August 21, 2008	Meeting	<ul style="list-style-type: none"> • This was the first meeting of the Conklin Resource Development Action Committee (CRDAC). • The purpose of the CRDAC was discussed. • The Terms of Reference for the CRDAC was discussed. • The structure of the CRDAC was discussed. • The style of presentations for the September 24, 2008 Conklin Trade Show was discussed. • Conklin Métis Local #193 consultant confirmed that the Conklin Métis Local #193 approved the KNOC, Conklin Métis Local #193 Joint Action Plan during their Board Meeting on August 20, 2008.
	September 15, 2008	Email	<ul style="list-style-type: none"> • Conklin Métis Local #193 Consultant sent email about the Conklin Trade Show, and the CRDAC meeting for September 23, 2008.
	September 23, 2008	Meeting	<ul style="list-style-type: none"> • This was a regularly scheduled meeting of the Conklin Resource Development Action Committee.
	September 24, 2008	Trade Show	<ul style="list-style-type: none"> • This was the Conklin Trade Show. • KNOC had a booth at the Trade Show and presented their project description information, including information on their 2008 Winter Works program. • No specific issues or concerns with the project were raised during the Trade Show.
	October 10, 2008	Email	<ul style="list-style-type: none"> • Conklin Métis Local #193 Consultant sent meeting minutes for CRDAC meeting which occurred on September 24, 2008.
	October 14, 2008	Email	<ul style="list-style-type: none"> • Conklin Métis Local #193 Consultant sent Agenda for CRDAC Meeting scheduled for October 19, 2008 to October 21, 2008.

Participant	Date	Method	Discussion Points
Conklin Métis Local #193 (cont)	October 19 to October 21, 2008	Meeting	<ul style="list-style-type: none"> • Conklin representatives characterized their community in the past and the present. They then discussed what they would like to see Conklin look like in the future. • The industry participants described the companies that they represent and some of the opportunities and challenges that they face. • A representative of ConocoPhillips gave a presentation on Enhanced Community Policing and stated that the RCMP are willing to place 2 officers in Janvier to patrol Janvier, Chard and Conklin if they are funded to do so. • A lawyer invited by the CRDAC gave a presentation on Aboriginal law and Métis rights in relation to the Duty to Consult. • The meeting participants reviewed the status of the society for the Conklin Resource Development Action Committee. • The industry participants had a private discussion to discuss the CRDAC funding formula. • It was agreed that a community investment society would be formed and that industry would develop a funding formula for it. • It was agreed that there would be an issues identification and verification process in Conklin on November 12, 2008. • It was agreed that the next CRDAC meeting would be on November 13, 2008.
	October 22, 2008	Email	<ul style="list-style-type: none"> • Conklin Métis Local #193 Consultant sent email explaining the cost for CRDAC Board Members who have attended previous sessions.
	November 12, 2008	Meeting	<ul style="list-style-type: none"> • Conklin Issues Identification Process Meeting: <ul style="list-style-type: none"> – the Elders met in the morning to identify issues faced by Conklin and to identify potential solutions to those issues. Sessions were facilitated and recorded by industry participants; – the youth met in the afternoon. The youth had prepared posters describing the most important issues facing the community. Industry representatives and the students discussed these posters, and the issues and concerns that they depicted as well as potential solutions; and – the adults met in the evening to discuss the issues and concerns faced by Conklin and potential solutions to those issues and concerns. Industry representatives facilitated and recorded these discussions.

Participant	Date	Method	Discussion Points
Conklin Métis Local #193 (cont)	November 13, 2008	Meeting	<ul style="list-style-type: none"> • This was a meeting of the CRDAC. • Industry participants described the funding which had been agreed to and how the CRDAC would be funded for 2008 and 2009. • It was explained that based on funding from some companies, the RCMP have begun playing Conklin, Chard and Janvier. • Conklin Métis Local #193 consultant explained that the Conklin Métis Local #193 and Conklin Community Association will provide a letter to the regulators explaining the CRDAC process. • CRDAC Advisor explained that the CRDAC Issues Identification Report from the May 2008 meeting is ready for distribution. • The issues identification process held on November 12, 2008 was discussed and all participants explained that they thought it was useful. • The status of the CRDAC and Community Enhancement Society was discussed.
	November 25, 2008	Meeting	<ul style="list-style-type: none"> • This was a Conklin Coffee House: <ul style="list-style-type: none"> – RCMP gave a presentation about their contract and presence in the Conklin/Janvier area; – Conklin Métis Local #193 Consultant gave a presentation on the responsibility of industry to conduct consultation and the nature of consultation; and – industry gave a presentation on In-situ technology, including SAGD. The goal of the presentation was to inform residents of Conklin about the industry and the various technologies used.
	December 3, 2008	Email	<ul style="list-style-type: none"> • Conklin Métis Local #193 Consultant sent letter outlining request for funding from the industry partners of the CRDAC.

Participant	Date	Method	Discussion Points
Conklin Métis Local #193 (cont)	December 9, 2008	Meeting	<ul style="list-style-type: none"> • KNOC provided CRDAC with a cheque to cover their portion of the CRDAC fees for 2008. • Regularly scheduled meeting of the CRDAC. Discussion topics include: <ul style="list-style-type: none"> – CRDAC met with President of Métis Nation of Alberta Zone 1 to explain CRDAC process; – community has concerns about Regional Municipality of Wood Buffalo Housing Strategy; – Conklin Métis Local #193 Consultant met with AENV to explain CRDAC process; – CRDAC budget will be finalized soon; – community member and Industry Representative will co-chair future meetings; – concern raised about an industry organized training course not being run through the CRDAC; – reviewed terms of reference, staffing, and funding for the community enhancement society; – discussed community planning process; – agreement that the Coffee House held on November 25, 2008 was successful; – Conklin Christmas Party to be held on December 16, 2008. Discussed planning issues for the party; – Conklin Métis Local #193 Consultant agreed to circulate all Agendas and Briefing Notes of the CRDAC for 2008; – Conklin Métis Local #193 Consultant will send each company invoice for the Action Plans; – discussed TLU study; and – Conklin Métis Local #193 Consultant explained that the issues identification report will be ready and circulated at the end of December 2008.
	January 6, 2009	Telephone	<ul style="list-style-type: none"> • KNOC Representative asked about the status of the community issues identification report. Conklin Métis Local #193 Consultant stated that the report is complete and will be sent out to all industry representatives within the next few days. • KNOC Representative asked about the status of the various items identified in the Action Plan. Conklin Métis Local #193 Consultant stated that the Action Plan items are complete, as is the invoicing and she will email the package to KNOC Representative in the next few days. • Conklin Métis Local #193 Consultant stated that she will be sending an email requesting that KNOC provide the GIS shape files of their lease boundaries to FMA, so that they can provide an overlay of relevant TK and TLU information. Conklin Métis Local #193 Consultant stated that she would send an email in the afternoon of January 6, 2009 with the request and contact information about where the shape files should be sent.
	January 7, 2009	Email	<ul style="list-style-type: none"> • FMA representative sent an email requesting that KNOC provide FMA with the shape files for the footprint and lease area for the project. • KNOC Representative provided FMA with GIS shape files of the KNOC Black Gold Project lease, regional study, and terrestrial study area boundaries.

Participant	Date	Method	Discussion Points
Conklin Métis Local #193 (cont)	January 14, 2009	Meeting	<ul style="list-style-type: none"> • This was a regularly scheduled meeting of the Conklin Resource Development Action Committee. Discussion topics include: <ul style="list-style-type: none"> – introduction of the CRDAC to the Regional Municipality of Wood Buffalo; – discussion of the Community Enhancement Society. Appointments to the Society board were made. It was also agreed that a Board meeting would occur on February 3, 2008; – Conklin Métis Local #193 Consultant explained that she has discussed the CRDAC with AENV, and that AENV would also like to meet with industry; – a process to undertake community planning was presented. A meeting with community leadership will occur on February 3, 2009 to discuss the community planning process; – the bank account for the CRDAC has been set up in Lac La Biche; – a job posting will be posted for the CRDAC admin assistant position and will be awarded by February 8, 2009; – the CRDAC schedule will be revised and distributed by Conklin Métis Local #193 Consultant; and – Conklin Community Association and Conklin Métis Local #193 election schedule was discussed.
	January 15, 2009	Email	<ul style="list-style-type: none"> • Conklin Métis Local #193 Consultant emailed KNOC Representative and provided information related to the Conklin Métis Local #193 Traditional Use Study.
	January 21, 2009	Email	<ul style="list-style-type: none"> • KNOC Representative sent email to Conklin Métis Local #193 Consultant and a representative of the Conklin Community Association (to circulate to members of the CRDAC) requesting permission to supply firewood to Conklin residents.
	February 13, 2009	Telephone	<ul style="list-style-type: none"> • KNOC Representative phoned Conklin Métis Local #193 Consultant to discuss whether the community wanted firewood delivered and to discuss the TLUOS study.
	February 18, 2009	Telephone	<ul style="list-style-type: none"> • Conklin Métis Local #193 Consultant explained that the community of Conklin does not want firewood delivered to the community. Apparently, the community has sufficient firewood, and some of it is rotting.
	February 25, 2009	Meeting	<ul style="list-style-type: none"> • This was a Conklin Community Coffee House: <ul style="list-style-type: none"> – RCMP provided an update on policing in the area; – Conklin Métis Local #193 Consultant gave a presentation describing the purpose and responsibility of industry to consult; and – a Devon drilling engineer gave a presentation to the attendees about drilling. The presentation was hosted by all industry companies part of the CRDAC and was about general drilling in the area (not focused on Devon's program).

Participant	Date	Method	Discussion Points
Conklin Métis Local #193 (cont)	February 26, 2009	Meeting	<ul style="list-style-type: none"> • This was a regularly scheduled meeting of the CRDAC. Key discussion topics included: <ul style="list-style-type: none"> – a representative of the Elders in Conklin will now be a regular participant in the CRDAC; – the Conklin Métis Local #193 made a financial contribution to the Community Enhancement Society; – it was agreed that the Trade Shows hosted by the CRDAC will remain the primary body to consult with the community at large about industrial projects’; – Conklin Métis Local #193 Consultant and industry participants met with AENV representatives to explain the CRDAC process, and determine if AENV will meet with Conklin to explain the review process; – the Conklin Métis Local #193 Consultant confirmed that the Regional Municipality of Wood Buffalo has committed funds to the CRDAC process; – the Conklin Métis Local #193 Consultant explained that the Community Issues ID process report has been prepared and will be circulated during the week of March 2, 2009.
	March 18, 2009	Meeting	<ul style="list-style-type: none"> • This was a regularly scheduled monthly meeting of the Conklin Resource Development Action Committee. Key discussion topics included: <ul style="list-style-type: none"> – the need to manage information and ensure that all affected stakeholders support the process; – a process to involve the Regional Municipality of Wood Buffalo in the CRDAC process; – the relationship between the CRDAC and company specific action plans; – community interface events including the Trade Show, Aboriginal Métis Days, and the Coffee Houses; – the community planning process; – CRDAC job descriptions and postings; – CRDAC schedule; – CRDAC budget; – results of the Conklin Métis Local #193 election; and – the need for a CRDAC annual report.
	April 21, 2009	Meetings	<ul style="list-style-type: none"> • KNOG representative and representative of ConocoPhillips facilitated issues management process meetings. • A session was held with the Elders in morning and early afternoon. A session was held with the youth in school during the late afternoon. In the evening, a session was held with the Adults. • During the sessions information collected during previous issues management process meetings was presented for verification and additions. • Small working groups were organized for meeting participants to provide a response. • Results of the meetings will be incorporated into the Community Planning process.

Participant	Date	Method	Discussion Points
Conklin Métis Local #193 (cont)	April 22, 2009	Meeting	<ul style="list-style-type: none"> This was a regularly scheduled meeting of the Conklin Resource Development Advisory Council. Discussion topics included: <ul style="list-style-type: none"> – the need for a CRDAC annual report, the policing program being funded by industry; – the need for a CRDAC annual report, the CRDAC’s meeting with the RMWB; – the need for a CRDAC annual report, CRDAC deliverables; – the need for a CRDAC annual report, industry deliverables; – the need for a CRDAC annual report, the community issues management process; – the need for a CRDAC annual report, the facility and site location for the CRDAC office; and – the need for a CRDAC annual report, the enhancement society.
	May 8, 2009	Email	<ul style="list-style-type: none"> KNOC representative sent CRDAC Advisor a copy of the draft materials that they were planning on presenting at the Conklin Trade Show and requested CRDAC Advisor review to determine if the format and materials are suitable, and presented in a manner that was agreed upon with the CRDAC and other industry partners.
	May 11, 2009	Email and telephone	<ul style="list-style-type: none"> CRDAC Advisor sent email stating that the draft materials KNOC prepared for the Conklin Trade Show was well done. She followed up with a phone call confirming that they were appropriate for the Trade Show.
	May 13, 2009	Meeting	<ul style="list-style-type: none"> This was a regularly scheduled meeting of the Conklin Resource Advisory Council.
	May 14, 2009	Email	<ul style="list-style-type: none"> CRDAC Advisor sent an email containing an invoice for KNOC action plan.
	May 14, 2009	Trade Show	<ul style="list-style-type: none"> This was the Conklin Trade Show. KNOC had a booth with materials describing their project. More than 40 residents of Conklin attended the KNOC booth. No project-specific concerns were raised by participants at the Trade Show.
	June 17, 2009	Coffee House	<ul style="list-style-type: none"> CRDAC organized coffee house for residents of Conklin. CRDAC Advisor provided a description of the CRDAC process, including coffee houses, tradeshow, etc. Alberta Environment representatives made a presentation on the approvals process, water and how they regulate it, and how it is affected by oilsands development. Industry representatives responded to questions posed by community members at a previous coffee house.
	June 18, 2009	Meeting	<ul style="list-style-type: none"> This was a regularly scheduled meeting of the Conklin Resource Development Advisory Council.
	August 10, 2009	Email	<ul style="list-style-type: none"> Chris O’Neil sent a Draft CRDAC Bulletin about the KNOC BlackGold Project to CRDAC Advisor for her review and comment.

Participant	Date	Method	Discussion Points
Conklin Métis Local #193 (cont)	August 17, 2009	Telephone	<ul style="list-style-type: none"> CRDAC Advisor called KNOC representative. CRDAC Advisor explained that the template for the CRDAC Bulletin has been somewhat revised. CRDAC Advisor also suggested that a few revisions would be required to the bulletin. In particular she suggested that the text should be minimized and also thought that it would be appropriate to omit contact information for KNOC and only include CRDAC contact information.
	August 19, 2009	Telephone	<ul style="list-style-type: none"> KNOC representative called CRDAC Advisor to discuss CRDAC bulletin about the BlackGold Project. CRDAC Advisor requested that KNOC representative call on the morning of August 21, 2009.
	August 21, 2009	Telephone	<ul style="list-style-type: none"> KNOC representative called and left a voicemail for CRDAC Advisor. He explained that he was calling as requested about the CRDAC Bulletin. He requested that CRDAC Advisor return the call.
	September 9, 2009	Trade Show	<ul style="list-style-type: none"> KNOC participated in the Conklin Trade Show organized by the Conklin Resource Development Advisory Committee. KNOC had a booth at the Trade Show. KNOC provided information about the project and proposed 2009-2010 OSE program. KNOC also provided the CRDAC Bulletin about the KNOC project at their booth. No site-specific issues and concerns were raised.
	September 10, 2009	Meeting	<ul style="list-style-type: none"> This was a regularly scheduled meeting of the CRDAC.
	October 1, 2009 and October 2, 2009	Meeting	<ul style="list-style-type: none"> Conklin Resource Development Advisory Retreat to evaluate the CRRDAC and develop a go forward approach.
	October 15, 2009	Telephone	<ul style="list-style-type: none"> KNOC Representative called CRDAC Advisor to arrange a meeting to discuss the benefits agreement. KNOC representative also inquired about the Conklin Métis TK Study and whether it was a public document. CRDAC Advisor stated that it should be referred to as a preliminary draft.
	October 15, 2009	Email	<ul style="list-style-type: none"> KNOC representative sent CRDAC Advisor an email. Email contains a plain language summary and a project summary table for the BlackGold Expansion Project.
	October 22, 2009	Telephone	<ul style="list-style-type: none"> CRDAC Advisor left voicemail for KNOC representative stating that she would be available on the afternoon of November 4, 2009 to discuss the CRDAC benefits agreement.
	October 22, 2009	Email	<ul style="list-style-type: none"> KNOC representative sent a meeting invitation and explained that KNOC would be available to meet on November 4, 2009 in Calgary.
	October 27, 2009	Meeting	<ul style="list-style-type: none"> This was a regularly scheduled meeting of the CRDAC.
November 3, 2009	Email	<ul style="list-style-type: none"> CRDAC Advisor sent email with several attachments, including an Agenda, an outline for negotiating an Agreement in Principle, a handout on Constructive Engagement, a presentation on Constructive Engagement, a negotiator authorization letter, and the draft agreement that was first distributed in March 2009. Email requested that files be printed for meeting scheduled on November 4, 2009. 	

Participant	Date	Method	Discussion Points
Conklin Métis Local #193 (cont)	November 4, 2009	Meeting	<ul style="list-style-type: none"> • The purpose of this meeting was to discuss an Agreement in Principle between the CRDAC and KNOC. • CRDAC Advisor explained that the CRDAC would like to have an Agreement in Principle in place with each developer that is a part of the CRDAC by December 30, 2009. • CRDAC Advisor explained that the Agreement in Principle will form the basis of a longer term agreement. • CRDAC Advisor indicated that the CRDAC would like to have the long term agreement in place by the end of the first quarter in 2010. • CRDAC Advisor explained that the agreement in principle will not be legally binding. • CRDAC Advisor presented a presentation entitled 'Constructive and Honorable Engagement'. • CRDAC Advisor explained that key community interests include housing, protection of Christina Lake, and managing their own destiny. She also explained that the residents of Conklin want to benefit from development. • CRDAC Advisor provided a handout entitled 'Constructive and Honorable Engagement What Are the Challenges'. • It was suggested that the Agreement in Principle should address the following: <ul style="list-style-type: none"> – identify the parties and structure relationship to the agreement; – introduction or preamble; – purpose; – guiding principles; – term; – objectives; – administration; – schedules; and – costs. • CRDAC Advisor discussed the structure of the long-term agreement. She suggested that the CRDAC lawyers would draft the body of the agreement and it would be provided to KNOC by November 18, 2009. • CRDAC Advisor indicated that the CRDAC would like KNOC to commit to a negotiator and provide them with a letter indicating who the negotiating team for KNOC will be. • CRDAC Advisor indicated that KNOC will need to sign an action plan and that she and KNOC representative had discussions about it. • CRDAC Advisor indicated that the Conklin Community Enhancement Society has been set up to handle financial contributions to the community. She indicated that the CRDAC would be expecting contributions to the community based on production volumes. • CRDAC Advisor also mentioned that the CCES has explored the option of setting up co-op businesses. • CRDAC Advisor explained that the Conklin Métis had completed a traditional knowledge study, which should be considered a pre-baseline report because only the Elders were interviewed. • CRDAC Advisor explained that the Conklin Métis Local 193 provided KNOC with relevant GIS Shape files from the traditional knowledge study.

Participant	Date	Method	Discussion Points
Conklin Métis Local #193 (cont)	November 16, 2009	Email	<ul style="list-style-type: none"> • CRDAC Advisor sent revised CRDAC schedule for 2009 and Issues Management Process notice. • Email requested that CRDAC industry partners inform CRDAC Advisor whether they would be attending issues ID process meeting on November 17, 2009 and the CRDAC meeting on November 18, 2009. • Email stated that CRDAC agenda would be provided on November 18, 2009 and that discussions would include: issues management, the proposed Agreement-in-Principle, 2010 CRDAC schedule, CML #193's letter of concern and options available to companies not a part of the CRDAC. • Email stated that 2010 CRDAC schedule would follow later on November 18, 2009.
	November 16, 2009	Email	<ul style="list-style-type: none"> • KNOC representative sent email to CRDAC Advisor stating that he would attend the issues ID process on November 17, 2009 and the CRDAC meeting on November 18, 2009.
	November 17, 2009	Meetings	<ul style="list-style-type: none"> • The CRDAC held an issues identification process to identify and validate issues of the residents of Conklin. Three separate sessions were held: Elders, youth, and Adults. Approximately 10 Elders, 6 youth, and 20 adults attended the sessions. • Key issues and concerns validated include: <ul style="list-style-type: none"> – ensure no development around Christina Lake; – ensure traditional sites are put in place and protected – Wassassai is a key site; – ensure Conklin remains an Aboriginal/Métis community; – manage cultural change; – ensure land is secured for the future to address housing and business opportunity needs; – ensure housing concerns are manage effectively; and – ensure tax issues are addressed.
	November 18, 2009	Meeting	<ul style="list-style-type: none"> • This was a regularly scheduled CRDAC meeting. Discussion topics included: <ul style="list-style-type: none"> – agreement in principle; – legal analysis of Conklin Métis Local #193 Traditional Land Use Study; – handouts from Devon regarding the AIP; – CML #193 Letters of Concern; – options to companies without an agreement in principle; – industry takeaways; and – 2010 CRDAC Schedule.
	November 24, 2009	Email	<ul style="list-style-type: none"> • CRDAC Administrative Coordinator sent letter authorizing CRDAC Advisor to negotiate Agreement-in-Principle on behalf of Conklin, letter sent by Regional Municipality of Wood Buffalo to Conklin Métis Local #193, results of CRDAC Trade Show on September 9, 2009.

Participant	Date	Method	Discussion Points
Conklin Métis Local #193 (cont)	November 26, 2009	Email	<ul style="list-style-type: none"> • CRDAC Administrator responded to KNOC representatives email from November 29, 2009. • Email from CRDAC Administrator contained Conklin Community Enhancement Society donation request letter, invoice for the Conklin TLUS study, and a copy of the 2008 KNOC CRDAC Action Plan.
	November 26, 2009	Email	<ul style="list-style-type: none"> • KNOC representatives responded to CRDAC Administrator's email, sent earlier on November 26, 2009. • Email thanked CRDAC Administrator for providing the information and indicated that KNOC would respond as soon as practical.
	November 27, 2009	Telephone	<ul style="list-style-type: none"> • CRDAC Advisor left a voicemail requesting that KNOC representative return the phone call.
	November 27, 2009	Telephone	<ul style="list-style-type: none"> • Conklin Métis Local #193 Advisor and KNOC representative discussed agreement in principle and CRDAC process. • Conklin Métis Local #193 Advisor expressed concern that KNOC had not provided the draft AIP to her. KNOC representatives explained that KNOC had hoped to have provided her with the draft, was still finalizing it, and would have it to the Conklin Métis Local #193 advisor as soon as practical. • Conklin Métis Local #193 Advisor expressed understanding that KNOC was negotiating an agreement with the Chipewyan Prairie Dene First Nation, and was concerned that they had not received the draft agreement-in-principle. KNOC representative explained that negotiations with Chipewyan Prairie Dene First Nation were separate from negotiations with the CRDAC and that both were proceeding
	November 27, 2009	Email	<ul style="list-style-type: none"> • CRDAC representative sent email requesting that KNOC representative call her.
	November 27, 2009	Email	<ul style="list-style-type: none"> • CRDAC Advisor sent email to KNOC representative. • Email stated that CRDAC was concerned about KNOC's lack of responsiveness in providing the CRDAC with a draft agreement-in-principle. • Email requested KNOC representative to call her, and stated that she had left a voicemail requesting that the KNOC representative call her.

Participant	Date	Method	Discussion Points
Conklin Métis Local #193 (cont)	November 29, 2009	Email	<ul style="list-style-type: none"> • KNOC representative sent email to CRDAC Advisor. • Email contained proposed agreement in principle. • Email confirmed that it had taken KNOC longer to complete the draft than originally anticipated. • Email stated that KNOC believes the AIP reflects everything discussed at the November 4, 2009 meeting including: <ul style="list-style-type: none"> – objectives and purpose consistent with those outlined by the CRDAC; – identification of appropriate schedules to be included in a formal Community Benefits Agreement – commitments for funding TLU, Administration costs of the CRDAC, costs associated with completing the Agreement-in-Principle; and – community investment for a committed period of time with a further commitment to negotiate additional community investment funding periods over a longer period of time. • Email stated that the draft AIP includes specific sums for Traditional Land Use, administration and AIP/CBA negotiation consistent with amounts discussed at the November 4, 2009 meeting. • Email explained that specific sums for community investment were not included because KNOC would like further discussion. • Email confirmed that KNOC would honour their original commitment for an initial three year funding period.
	November 30, 2009	Email	<ul style="list-style-type: none"> • CRDAC Advisor sent email. • Email stated that costs related to negotiating the AIP should be added to the Action Plan and requested that KNOC call her to discuss it. • Email stated that CRDAC was requesting that KNOC meet in Conklin sometime between December 7 and December 18, 2009 to discuss the Agreement-in-Principle. • Email stated that “all community agreement discussions” were on the bases that they were for the lifetime of the project. Email stated that discussions did include a renewal term every 3-5 years but not re-negotiation. Email suggested that because developers do not apply for 3 year approvals it is not in the interest of Conklin to enter agreements that are not for the lifetime of the project. • Email stated that the need to reach agreement-in-principle by December 31 was to ensure that the Conklin Métis Local #193 saw the merit in remaining in a non-assertion of rights process, the CRDAC, and that the message was delivered to all developers on October 1, 2009 at the CRDAC retreat. • Email stated that the production related to impact amounts verbally presented to KNOC and other companies that the CRDAC has met with is available to developers until December 31, 2009. • Email requested that Senior KNOC representatives contact CRDAC Advisor to arrange a meeting date in Conklin to discuss the matters further.
	November 30, 2009	Telephone	<ul style="list-style-type: none"> • KNOC representatives and CRDAC Advisor agreed to meet on December 15, 2009 in Conklin to discuss the agreement-in-principle.



Participant	Date	Method	Discussion Points
Fort McMurray Métis Nation Local #1935	November 2007	Telephone	<ul style="list-style-type: none">• Various attempts by KNOC to speak/meet with General Manager of Fort McMurray Métis Nation Local #1935. Messages left with Métis office.
	March 18, 2008	Telephone	<ul style="list-style-type: none">• KNOC left a message for Fort McMurray Métis Local #1935 General Manager to return call.
	March 19, 2008	Telephone	<ul style="list-style-type: none">• A meeting was agreed to on April 9, 2008.• General Manager explained that the Fort McMurray Métis Nation Local #1935 will outline why they should be consulted and describe the process that they wish to use to be consulted.
	April 3, 2008	Telephone	<ul style="list-style-type: none">• KNOC left a message for General Manager of Fort McMurray Métis Local #1935 to return.
	April 4, 2008	Telephone	<ul style="list-style-type: none">• General Manager of Fort McMurray Métis Local #1935 stated that the meeting scheduled for April 9, 2008 would need to be postponed because he had a conflict.• General Manager of Fort McMurray Métis Local #1935 and KNOC discussed the process that could be used to complete the consultation process for the project.
	April 25, 2008	Telephone	<ul style="list-style-type: none">• KNOC called General Manager of Fort McMurray Métis Local #1935 to determine if the meeting scheduled for April 29, 2008 could be rescheduled to May 7, 2008.• General Manager of Fort McMurray Métis Local #1935 replied that May 7, 2008 would work better for him and the meeting was rescheduled.
	April 30, 2008	Telephone	<ul style="list-style-type: none">• KNOC called General Manager of Fort McMurray Métis Local #1935 and left message for receptionist. KNOC called to reschedule meeting for May 7, 2008.
	May 7, 2008	Meeting	<ul style="list-style-type: none">• KNOC provided a hardcopy of the application to the Fort McMurray Métis Nation Local #1935.• KNOC introduced the project.• General Manager of Fort McMurray Métis Local #1935 described the history of Métis in Canada and the Fort McMurray Métis Nation Local #1935.• General Manager of Fort McMurray Métis Local #1935 described the priorities of the Fort McMurray Métis Nation Local #1935.• General Manager of Fort McMurray Métis Local #1935 outlined the consultation process that the Fort McMurray Métis Nation Local #1935 will want KNOC to follow.• The Fort McMurray Métis Nation Local #1935 agreed to provide KNOC with a consultation plan.• It was agreed that KNOC and the Fort McMurray Métis Nation Local #1935 would meet on May 22, 2008 to advance the consultation process.

Participant	Date	Method	Discussion Points
Fort McMurray Métis Nation Local #1935 (cont)	May 15, 2008	Telephone/email	<ul style="list-style-type: none"> The Fort McMurray Métis Local #1935 sent KNOC, a “2008 Commitment Action Plan Mitigation and Measures – Korea National Oil”. KNOC explained that he had reviewed the Commitment Action Plan and wanted to briefly discuss it so that he was sure that he understood it prior to the meeting scheduled for May 22, 2008. KNOC asked for clarification regarding the funding request by the Fort McMurray Métis Nation Local #1935. The Fort McMurray Métis Nation Local #1935 confirmed that was not requesting that KNOC fund all initiatives on the commitment action plan, but that they were hoping KNOC would support one or two of the initiatives. KNOC explained they were anticipating that the Fort McMurray Métis Nation Local #1935 would send a Draft Consultation Plan that would describe how the Fort McMurray Métis Nation Local #1935 wanted to undertake consultation, and that consultation was different from funding. The Fort McMurray Métis Nation Local #1935 stated that they would send a consultation plan, and that it was currently being editing it and would be sent on May 16, 2008.
	May 20, 2008	Telephone	<ul style="list-style-type: none"> KNOC called the Fort McMurray Métis Local #1935 to request that they send the draft consultation plan, so that KNOC will have an opportunity to review it prior to the meeting scheduled for May 22, 2008. KNOC asked about lunch arrangements for the meeting on May 22, 2008, and it was agreed that the Fort McMurray Métis Local #1935 would order lunch in, which KNOC would pay for.
	May 21, 2008	Email	<ul style="list-style-type: none"> The Fort McMurray Métis Local #1935 emailed a letter from the President of Fort McMurray Métis Nation Local #1935, which describes the relationship building process which they would like KNOC to engage in.
	May 22, 2008	Meeting	<ul style="list-style-type: none"> KNOC and the Fort McMurray Métis Nation Local #1935 met to discuss the relationship process letter which was sent to KNOC on May 21, 2008. KNOC and the Fort McMurray Métis Nation Local #1935 discussed the relationship letter in detail and agreed to a consultation process. It was agreed that the Fort McMurray Métis Nation Local #1935 would revise the relationship agreement based on the discussion and send a new version.
	May 26, 2008	Telephone	<ul style="list-style-type: none"> The Fort McMurray Métis Local #1935 representative stated that she would send the revised relationship agreement to KNOC either on May 26 or May 27, 2008.
	July 9, 2008	Meeting	<ul style="list-style-type: none"> The purpose of this meeting was for KNOC to make a presentation, describing KNOC and the project, to Fort McMurray Métis Nation Local #1935. KNOC presented an overview of the project. There were several questions during the presentation.
	July 15, 2008	Telephone	<ul style="list-style-type: none"> KNOC and the Fort McMurray Métis Local #1935 discussed the relationship building process and the draft documents describing that process. Several revisions to the document were discussed and it was agreed that the Fort McMurray Métis Nation Local #1935 would redraft the document.
	July 22, 2008	Email	<ul style="list-style-type: none"> The Fort McMurray Métis Local #1935 sent KNOC a revised draft of the Relationship Building agreement.

Participant	Date	Method	Discussion Points
Fort McMurray Métis Nation Local #1935 (cont)	July 23, 2008	Fax letter	<ul style="list-style-type: none"> The Fort McMurray Métis Local #1935 sent Mike Boyd, Director of Northern Region Alberta Environmental Regulatory Approvals Centre, a Progress Letter for KNOC BlackGold Project. The letter explains that KNOC and the Fort McMurray Métis Local #1935 have a good working relationship, and discussed some concerns they have about the project.
	September 11, 2008	Meeting	<ul style="list-style-type: none"> As requested by the Fort McMurray Métis Local #1935 KNOC attend an Elders meeting. KNOC presented 'KNOC BlackGold Project Overview' and responded to questions. KNOC also hosted a Meet and Greet for members of the Fort McMurray Métis Local #1935.
	September 17, 2008	Telephone	<ul style="list-style-type: none"> KNOC Representative called representative of the Fort McMurray Métis Local #1935 to confirm arrangements for the Elders Processing Session scheduled for September 25, 2008. Receptionist stated that representative of the Fort McMurray Métis Local #1935 was out of office until September 29, 2008.
	September 22, 2008	Telephone	<ul style="list-style-type: none"> KNOC Representative called representative of the Fort McMurray Métis Local #1935 to confirm arrangements for the Elders Processing Session scheduled for September 25, 2008. Representative of the Fort McMurray Métis Local #1935 explained that their consultant would not be available on September 25, 2008 and would not be available until October 9, 2008. KNOC Representative asked if the Fort McMurray Métis Local #1935 wanted KNOC to attend the session or attend a subsequent session. KNOC Representative explained his understanding of the documentation that the Fort McMurray Métis Local #1935 sent suggested that there would be two separate sessions. Fort McMurray Métis Local #1935 explained that the Fort McMurray Métis Local #1935 was still fine tuning their processes and were not sure whether they wanted KNOC to attend the session facilitated by their consultant or a subsequent session.
	September 25, 2008	Letter	<ul style="list-style-type: none"> Fort McMurray Métis Local #1935 sent KNOC Representative an invoice for Elders meeting and Meet and Greet.
	September 25, 2008	Telephone	<ul style="list-style-type: none"> KNOC Representative called representative of the Fort McMurray Métis Local #1935 to explain that there was an error on the invoice which was sent by the Fort McMurray Métis Local #1935. The KNOC representative explained that the invoice includes honoraria for 30 Elders, and only 19 were in attendance. KNOC representative also explained that there were some calculation errors on the invoice.
	September 29, 2008	Telephone	<ul style="list-style-type: none"> Representative of the Fort McMurray Métis Local #1935 sent revised invoice.
	October 7, 2008	Email	<ul style="list-style-type: none"> Consultant to the Fort McMurray Métis Local #1935 confirmed that he had received maps of the KNOC lease and that they would be acceptable for use in the TK/TLU workshop scheduled for October 9, 2009.
	November 5, 2008	Telephone	<ul style="list-style-type: none"> KNOC Representative called representative of the Fort McMurray Métis Local #1935 to discuss the action plan. Representative of the Fort McMurray Métis Local #1935 explained that he had resigned from the Fort McMurray Métis Local #1935 and suggested that KNOC Representative call, the President of the Fort McMurray Métis Local #1935.

Participant	Date	Method	Discussion Points
Fort McMurray Métis Nation Local #1935 (cont)	November 6, 2008	Telephone	<ul style="list-style-type: none"> • President of the Fort McMurray Métis Local #1935 returned KNOC representative's call. • KNOC representative explained his understanding that the general manager of the Fort McMurray Métis Local #1935 had resigned. • KNOC Representative explained that KNOC had been working with the general manager and had largely agreed to a Consultation Action Plan, and had in fact had undertaken many of the steps of the plan. KNOC representative explained that KNOC would like to discuss the plan with the President of the Fort McMurray Métis Local #1935, ensure that it was supported by the new Board and finalized. • It was suggested that a meeting occur on November 14, 2008.
	November 14, 2008	Meeting	<ul style="list-style-type: none"> • KNOC Representatives provided representative of the Fort McMurray Métis Local #1935, and a representative of the Wood Buffalo Métis Corporation with a project description. • KNOC Representatives explained that KNOC had been negotiating a relationship agreement with the Fort McMurray Métis Local #1935 and provided them details on the negotiations to date. • KNOC Representatives explained KNOC's negotiation strategy. • Representative from the Wood Buffalo Métis Corporation stated that the Wood Buffalo Métis Corporation represents the Willow Lake Métis and the Chard Métis and suggested that KNOC meet with them. He explained that he will set up the meeting with the other Métis locals.
	December 17, 2008	Email	<ul style="list-style-type: none"> • KNOC Representative sent email outlining the activities that have been undertaken to date. Attachments included a draft of the Consultation Agreement and the KNOC Project Overview to President of Fort McMurray Métis Local #1935 and Wood Buffalo Métis Corporation.
	January 12, 2009	Telephone	<ul style="list-style-type: none"> • KNOC Representative and representative of Wood Buffalo Métis Corporation discussed the draft consultation strategy. • Wood Buffalo Métis Corporation representative expressed his understanding that he should be paid to review the proposal. KNOC representative explained that the Fort McMurray Métis Nation Local #1935 and the Wood Buffalo Métis Corporation would be compensated for undertaking activities included in the action plan when that plan was agreed to and implemented.
	January 15, 2009	Email	<ul style="list-style-type: none"> • Wood Buffalo Métis Corporation representative sent email to KNOC Representative. • The email explained that the Fort McMurray Métis Local #1935 is requesting KNOC to cover operational expenses. The email also explained the Wood Buffalo Métis Corporations understanding that the draft agreement which was negotiated with the previous General Manager, of the Fort McMurray Métis Local #1935 does not cover enough areas, is not specific in its terminology and needs to be redrafted. • KNOC requested a detailed description of what the Fort McMurray Métis Nation Local #1935 would like included in a re-drafted agreement.

Participant	Date	Method	Discussion Points
Fort McMurray Métis Nation Local #1935 (cont)	February 4, 2009	Telephone	<ul style="list-style-type: none"> • KNOC Representative and representative of Wood Buffalo Métis Corporation discussed the draft consultation strategy. • The representative of the Wood Buffalo Métis Corporation reiterated his desire to be paid to negotiate a consultation plan. It was agreed that the Wood Buffalo Métis Corporation would send a proposal to negotiate the Consultation Plan by February 18, 2009. • There was a discussion about the process used to develop the draft consultation plan.
	February 23, 2009	Telephone	<ul style="list-style-type: none"> • KNOC Representative called representative of the Wood Buffalo Métis Corporation to discuss the status of the proposal to negotiate the consultation plan. • Representative of the Wood Buffalo Métis Corporation stated that he had not yet completed the plan and stated that he is hoping to complete the plan by February 25, 2009 and would send it to KNOC Representative when it is drafted.
	March 11, 2009	Telephone	<ul style="list-style-type: none"> • KNOC representative phoned representative of the Wood Buffalo Métis Corporation to determine the status of the proposal that the WBMC had committed to sending. Left message with receptionist requesting that WBMC representative return the call.
	March 13, 2009	Email	<ul style="list-style-type: none"> • KNOC representative forwarded a form letter from Métis Nation of Alberta #1935, signed by President of Métis Local #1935 stating that the Wood Buffalo Métis Corporation will no longer represent or advocate on behalf of Métis Local #1935 and that all contacts should be made through the General Manager, Fort McMurray Métis Local 1935.
	May 8, 2009	Email	<ul style="list-style-type: none"> • Email sent by President of Fort McMurray Métis Local #1935 explaining that previous General Manager is no longer employed. • Email stated that future contacts should be directed to President of Métis Local #1935.
	June 9, 2009	Telephone	<ul style="list-style-type: none"> • KNOC representative called President of Fort McMurray Métis Local #1935 to arrange a meeting to discuss the consultation plan. • It was agreed that the meeting would occur on June 17, 2009 at 3:00pm at the Fort McMurray Métis Local #1935 office. • President of Fort McMurray Métis Local #1935 indicated that he had recently hired a new general manager for the Fort McMurray Métis Local #1935 who would likely attend the meeting. • KNOC representative explained that previously the Fort McMurray Métis Local #1935 and KNOC had essentially come to an agreement on a consultation Action Plan. KNOC explained that many of the activities identified on the Consultation Action Plan were complete. However, the Consultation Action Plan had not been signed and KNOC could not provide funds to the Fort McMurray Métis Local #1935 until the agreement was signed. • KNOC representative agreed to provide the President of the Fort McMurray Métis Local #1935 with a copy of the draft agreement prior to the meeting on June 17, 2009.

Participant	Date	Method	Discussion Points
Fort McMurray Métis Nation Local #1935 (cont)	June 9, 2009	Email	<ul style="list-style-type: none"> • KNOC representative sent President of Fort McMurray Métis Local #1935 with a copy of the Consultation Action Plan that was previously agreed to. • Email describes potential next steps, if Fort McMurray Métis Local #1935 agrees to the draft Consultation Action Plan.
	June 11, 2009	Email	<ul style="list-style-type: none"> • President of Fort McMurray Métis Local #1935 sent email. • Email identified new General Manager of the Fort McMurray Métis Local #1935.
	June 17, 2009	Meeting	<ul style="list-style-type: none"> • KNOC provided a description of the engagement and consultation that KNOC has undertaken with the Fort McMurray Métis Local #1935 to the new General Manger. Discussion focused on the draft consultation plan, the activities that have occurred to date and a discussion of next steps.
	June 6, 2009	Telephone	<ul style="list-style-type: none"> • KNOC representative called and left a message with the receptionist for General Manager of Fort McMurray Métis Local #1935 to return his call.
	June 8, 2009	Telephone	<ul style="list-style-type: none"> • KNOC representative called General Manager to follow-up on June 17, 2009 meeting. • KNOC representative asked if General Manager had an opportunity to review the KNOC file and decide how the Fort McMurray Métis Local #1935 would like to proceed. • General Manager explained that she is still getting up to speed on a number of files, trying to hire staff and trying to organize the office. She reminded KNOC that the Fort McMurray Métis Local #1935 has had two previous General Managers in the last year. • KNOC representative expressed his understanding of the situation the General Manager was addressing. • KNOC representative explained that KNOC is anticipating that the ERCB will contact the Fort McMurray Métis Local #1935 in the next few weeks to determine whether they had any issues and concerns with the BlackGold Project. • It was agreed that KNOC representative and General Manager would contact each other within the next few weeks to determine next steps.
	August 10, 2009	Telephone	<ul style="list-style-type: none"> • KNOC representative called General Manager to follow-up on previous discussions. • Receptionist stated that General Manager was on holiday until August 17, 2009.
	August 21, 2009	Telephone	<ul style="list-style-type: none"> • KNOC representative left a voicemail requesting that General Manager return the call.
	September 3, 2009	Telephone	<ul style="list-style-type: none"> • KNOC representative phoned and left a message with staff of Fort McMurray Métis Local #1935 for General Manager to return the call. KNOC representative explained that he had previously spoken with General Manager and wanted to follow-up on that meeting to discuss next steps.
	September 3, 2009	Telephone	<ul style="list-style-type: none"> • Fort McMurray Métis Local #1935 representative called KNOC representative to state that next steps were to meet with General Manager. • KNOC representative asked if a meeting could be scheduled for September 9, 2009. • Fort McMurray Métis Local #1935 agreed that the meeting could be scheduled

Participant	Date	Method	Discussion Points
Fort McMurray Métis Nation Local #1935 (cont)	September 9, 2009	Meeting	<ul style="list-style-type: none"> • KNOC and Fort McMurray Métis Local #1935 discussed the status of the Consultation Plan and outstanding invoices. • Fort McMurray Métis Local #1935 stated that there are outstanding invoices to KNOC. • KNOC representatives explained the process that was used to develop the draft consultation plan, and the action steps associated with the invoices. They explained that the invoices cannot be paid until the Consultation Agreement is signed, and that as soon as it is signed, KNOC will pay the invoices. • Fort McMurray Métis Local #1935 representatives provided information about a joint venture arrangement with a company that provides camp catering services.
	October 15, 2009	Telephone	<ul style="list-style-type: none"> • KNOC representative called General Manager. Receptionist stated that General Manager was out of the office and would return on October 16, 2009. • KNOC representative explained that he would call General Manager on October 16, 2009.
	October 16, 2009	Telephone	<ul style="list-style-type: none"> • KNOC representative called General Manager. • KNOC representative explained that he was calling to follow up on the September 9, 2009 meeting. He asked if the Fort McMurray Métis Local #1935 had an opportunity to review the consultation plan. KNOC representative explained that KNOC is keen to advance the process. General Manager explained that a member of her staff is taking care of the file and would call KNOC representative on September 19, 2009. • KNOC representative explained that KNOC is also planning an expansion project. It was agreed that KNOC representative would send the plain language summary and project summary sheet to Fort McMurray Métis Local #1935 by email.
	October 16, 2009	Email	<ul style="list-style-type: none"> • KNOC representative emailed Fort McMurray Métis Local #1935. • Email contained Plain Language Summary and Project Summary Table for KNOC BlackGold Expansion Project. • Email also states that KNOC looks forward to advancing the consultation plan.
	October 21, 2009	Telephone	<ul style="list-style-type: none"> • KNOC representative left a message requesting that the call be returned. • Receptionist explained that Fort McMurray Métis Local #1935 was traveling and might not be able to return the call until October 26, 2009. KNOC representative explained that he would be out of the office on October 26, 2009 and October 27, 2009.
	November 4, 2009	Telephone	<ul style="list-style-type: none"> • Fort McMurray Métis Local #1935 representative returned KNOC representatives call, left a voicemail, and asked him to return the call.
	November 4, 2009	Telephone	<ul style="list-style-type: none"> • KNOC representative left a message with the receptionist requesting that Fort McMurray Métis Local #1935 representative call him.
	November 4, 2009	Telephone	<ul style="list-style-type: none"> • Fort McMurray Métis Local #1935 returned KNOC representatives phone call and it was agreed that a meeting would occur on November 4, 2009 to discuss the consultation plan.

Participant	Date	Method	Discussion Points
Fort McMurray Métis Nation Local #1935 (cont)	November 5, 2009	Meeting	<ul style="list-style-type: none"> • General Manager explained that the Fort McMurray Métis Local 1935 had reviewed the draft consultation agreement and had a few suggested revisions. • Proposed changes were identified. The proposed changes were relatively minor, and KNOC indicated that they would review them more fully, but would likely accept all of the changes. • The Fort McMurray Métis Local #1935 presented a work plan to accompany the Consultation Agreement. The work plan described proposed commitments and payments from KNOC to the Fort McMurray Métis Local 1935. KNOC indicated that they would review the proposed commitments and respond to the Fort McMurray Métis Local 1935. • KNOC representative confirmed that the Fort McMurray Métis Local 1935 had received information on KNOC's expansion plans. It was agreed that a second action plan would be developed for that project.
	November 10, 2009	Email	<ul style="list-style-type: none"> • Fort McMurray Métis Local #1935 representative sent email responding to a request from KNOC. • Email indicated that other companies with operations near the KNOC BlackGold lease have contributed to the Mark of the Métis study.
	November 13, 2009	Telephone	<ul style="list-style-type: none"> • KNOC called Fort McMurray Métis Local #1935 representative to request permission to use the results from the Fort McMurray Métis Local #1935s draft report in the environmental assessment for the Expansion Project. • Fort McMurray Métis Local #1935 representative stated that they would consider the request and respond on November 24, 2009. • Fort McMurray Métis Local #1935 requested that KNOC representative forward a copy of the draft report to her.
	November 23, 2009	Email	<ul style="list-style-type: none"> • KNOC representative sent email to Fort McMurray Métis Local #1935 representative. • Email contained Fort McMurray Métis Local #1935 Draft TK study prepared by Ken Shipley. • Email explained that KNOC is hoping to use the draft report in their assessment for the Expansion Project. Email also explained that if the Fort McMurray Métis Local #1935 made changes to the final report, which affected the environmental assessment, then KNOC would notify the regulators of those changes.
	November 24, 2009	Telephone	<ul style="list-style-type: none"> • KNOC representative phoned Fort McMurray Métis Local #1935 representative to determine if KNOC could use the draft Fort McMurray Métis Local #1935 Draft TK Study. • Fort McMurray Métis Local #1935 stated that they still had not made a determination, understood and urgency would respond as soon as practical.
	November 26, 2009	Telephone	<ul style="list-style-type: none"> • KNOC representative and Fort McMurray Métis Local #1935 representatives discussed whether KNOC could use the draft Fort McMurray Métis Local #1935 TK study as a part of their Expansion Project application. • Fort McMurray Métis Local #1935 representative indicated that because a consultation plan had not been formally agreed upon, and the outstanding invoices had not yet been paid, they would not give KNOC permission to use the draft report. • KNOC representative explained that they understood the position and would work to finalize the consultation plan as soon as practical.

Participant	Date	Method	Discussion Points
Chard Métis Local #214	January 14, 2007	Telephone	<ul style="list-style-type: none"> • KNOC introduced the project to the President of the Chard Métis Local #214. Explained that KNOC would like to meet with the Chard Métis Local #214. • Chard Métis Local #214 explained that they would like to meet, but would likely be unable to do so until at least February 18, 2008 and would contact KNOC about when they would like to meet. • Chard Métis Local #214 explained that they belong to the Wood Buffalo Métis Corporation and consultation activities might be arranged by the Wood Buffalo Métis Corporation.
	March 17, 2008	Telephone	<ul style="list-style-type: none"> • KNOC called to arrange a meeting with the WBMC. • Wood Buffalo Métis Corporation suggested that the meeting should occur on May 10, 2008 and suggested that KNOC send him an email.
	March 18, 2008	Email	<ul style="list-style-type: none"> • KNOC sent email to confirm meeting request for May 10, 2008.
	March 19, 2008	Telephone	<ul style="list-style-type: none"> • KNOC contacted President of the Chard Métis Local #214 to arrange a meeting. • President of the Chard Métis Local #214 confirmed that they were a member of the WBMC and suggested that a meeting on April 10, 2008 would be acceptable. • President of the Chard Métis Local #214 requested that a copy of the application for 10,000 bpd be sent to the Wood Buffalo Métis Corporation.
	April 2, 2008	Telephone	<ul style="list-style-type: none"> • President of the Chard Métis Local #214 left a voice mail message for KNOC explaining that the meeting scheduled for April 10, 2008 would need to be rescheduled. She explained that she had conflicts and did not have time to prepare for the meeting. She suggested that it would need to be postponed until May.
	April 15, 2008	Telephone	<ul style="list-style-type: none"> • KNOC called to reschedule the meeting originally scheduled for April 9, 2008. • Wood Buffalo Métis Corporation explained that in his mind, the Chard Métis Local #214 will be the most impacted Métis Group. He suggested consultation should occur with them. • Wood Buffalo Métis Corporation stated that he would speak with the President of the Chard Métis Local #214 to arrange a meeting. He committed to calling KNOC on the morning of April 16, 2008 to make arrangements for the meeting. • Wood Buffalo Métis Corporation stated that the President and Board Members for the Willow Lake Métis all have full time jobs, and their meetings tend to occur on the weekend. KNOC explained that KNOC will meet with them on the weekend.
	April 22, 2008	Telephone	<ul style="list-style-type: none"> • KNOC called Wood Buffalo Métis Corporation to determine if they had spoken with the President of the Chard Métis Local #214 and to determine if a meeting could be arranged for the week of April 28, 2008. • Wood Buffalo Métis Corporation stated that they had not yet spoken with Darlene Herman, had it on his list of things to do and would contact KNOC by April 25, 2008.

Participant	Date	Method	Discussion Points
Chard Métis Local #214 (cont)	April 29, 2008	Telephone	<ul style="list-style-type: none"> President of the Chard Métis Local #214 left a voicemail for KNOC stating that she would like to meet on June 3, 2008 in Fort McMurray. She asked KNOC to call back and confirm the meeting. President of the Chard Métis Local #214 called back and left a voicemail to suggest that they could now meet on May 15, 2008 in Fort McMurray. KNOC returned President of the Chard Métis Local #214 call and suggested that May 15, 2008 would likely work as a meeting date.
	May 1, 2008	Telephone	<ul style="list-style-type: none"> KNOC called President of the Chard Métis Local #214 to inform her that KNOC would be unavailable to meet on May 15, 2008 due to a schedule conflict. President of the Chard Métis Local #214 suggested that a meeting occur on May 22, 2008. KNOC stated that he would check with KNOC and notify her if they would be able to meet on May 22, 2008. President of the Chard Métis Local #214 explained that she wants this meeting to occur in Fort McMurray and be held between KNOC and herself. She suggested that a subsequent meeting would need to occur to which Elders and Board Members should be invited. KNOC agreed that the meeting could occur with the President of the Chard Métis Local #214 and that a subsequent meeting with the Elders and Board Members would be fine. KNOC explained that they wanted the Chard Métis Local #214 to describe the consultation process that they would like KNOC to engage in.
	May 22, 2008	Meeting	<ul style="list-style-type: none"> KNOC met with the Chard Métis Local #214 and the WBMC to introduce KNOC and the Black Gold Project. Discussed the preferred consultation process.
	June 6, 2008	Telephone	<ul style="list-style-type: none"> KNOC left a message on voicemail for the President of the Chard Métis Local #214 to return call. President of the Chard Métis Local #214 called to discuss meeting tentatively scheduled for June 11, 2008.
	September 9, 2009	Telephone	<ul style="list-style-type: none"> KNOC representative spoke with Vice President of Chard Métis Local #213 to get up to date contact information. KNOC representative explained that the ERCB required the contact information because they wished to send the Chard Métis Local #214 information about the regulatory process regarding the KNOC project. KNOC representative also explained that the Chard Métis Local #214 would have two weeks to respond to the letter once it was received. Vice President of Chard Métis Local #214 provided a fax number for the Chard Métis Local #214 and stated it should be addressed to President of Chard Métis Local #214. KNOC representative also reminded Vice President of Chard Métis Local #214 that KNOC had been working with the Chard Métis Local #214 and with other industry partners and the Wood Buffalo Métis Corporation was trying to develop a consultation model. Vice President stated that the Chard Métis Local #214 was not working with the Wood Buffalo Métis Corporation anymore. Vice President stated that the Chard Métis Local #214 would arrange a meeting with industry partners to develop a consultation strategy.
Métis Nation of Alberta Zone 1	May 28, 2008	Letter	<ul style="list-style-type: none"> Métis Nation of Alberta Zone 1 sent letter to AENV expressing disappointment that KNOC did not consult with them about the project and expressing a desire for preliminary information about the project.

Participant	Date	Method	Discussion Points
Métis Nation of Alberta Zone 1 (cont)	May 29, 2008	Telephone	<ul style="list-style-type: none"> • KNOC called and left a message for Ken Bourque to call back. • Myles Arnfinson returned call from KNOC to Ken Bourque, President, Métis Nation of Alberta Zone 1. • KNOC had received the letter which the Métis Nation of Alberta Zone 1 sent to AENV. KNOC has engaged and consulted with the Conklin Métis Local #193, the Chard Métis Local #214 and the Fort McMurray Métis Local #1935. KNOC also explained that if the Métis Nation of Alberta Zone 1 would like information about the project, KNOC would provide it. KNOC asked how the Métis Nation of Alberta Zone 1 would prefer to receive the information. Myles stated that they would like to arrange a meeting.
	August 19, 2008	Telephone	<ul style="list-style-type: none"> • KNOC called and left a message for Myles to return his call. • Myles Arnfinson returned KNOC's phone call from earlier in the day. • KNOC explained that as previously discussed, KNOC would like to meet with the Métis Nation of Alberta Zone One and wondered if they would be available to meet on September 3, 2008. • Myles Arnfinson stated that the Métis Nation of Alberta Zone One would not be able to meet until around mid-September. He stated that he would contact KNOC on September 10, 2008 to arrange a meeting date.
	December 3, 2008	Telephone	<ul style="list-style-type: none"> • KNOC contacted new President of Métis Nation of Alberta Zone 1. • KNOC Representative explained that the KNOC BlackGold Project is approximately 10 km southeast of Conklin. • KNOC Representative explained that KNOC has been engaging and consulting with the Conklin Métis Local #193, the Fort McMurray Métis Local #1935, and the Chard Métis Local #213. • KNOC Representative also explained that the Métis Nation of Alberta Zone 1 had sent a statement of concern to AENV. KNOC representative explained that he had contacted the Métis Nation of Alberta Zone 1 and explained that they would consult with and had sent the application to them. • KNOC Representative explained that he had phoned the President, Métis Nation of Alberta Zone 1 to better understand how the Métis Nation of Alberta Zone 1 would like to be engaged and consulted. • The president explained that the Métis Nation of Alberta is currently developing a consultation policy. • The president requested that KNOC representative send him information about the project. The KNOC representative explained that he would send a presentation. The KNOC representative also stated that the applications which were submitted to AENV and the ERCB had been sent to the Métis Nation of Alberta Zone 1. The president of the Métis Nation of Alberta Zone 1 stated that it was not required to resend the information. • The President of the Métis Nation of Alberta Zone 1 stated that Rick Boucher authority to act on behalf of the Métis Nation of Alberta Zone 1 has been stripped and that KNOC should not respond to any requests from him.

Participant	Date	Method	Discussion Points
Métis Nation of Alberta Zone 1 (cont)	December 4, 2008	Email	<ul style="list-style-type: none"> • KNOC Representative sent email to the President of the Métis Nation of Alberta Zone 1. • KNOC Representative provided, as an attachment, a project overview of the KNOC project. • KNOC Representative stated that copies of the application submitted to AENV and the ERCB had been sent to the Métis Nation of Alberta Zone 1, the Fort McMurray Métis Local #1935 and other Aboriginal stakeholders. • KNOC Representative asked how the Métis Nation of Alberta would like to be engaged and consulted in the process and asked Bill to let him know.
	October 15, 2009	Telephone	<ul style="list-style-type: none"> • KNOC representative called President of Métis Nation of Alberta Region One to discuss the KNOC BlackGold Expansion Project. • KNOC representative explained that KNOC has prepared a Plain Language Summary and a Project Summary Table and asked what the best way to share them with the Métis Nation of Alberta Region 1. President of Métis Nation of Alberta Region One stated that the best method would be email. • KNOC representative asked how the Métis Nation of Alberta Region 1 would like to be engaged and consulted. President of Métis Nation of Alberta Region One replied that the Region is working on a consultation policy, but that they do not have a policy in place yet. • President of Métis Nation of Alberta Region One also expressed frustration with the Government of Alberta because they do not have a Métis Consultation policy. He explained that the Métis do want to be consulted. • President of Métis Nation of Alberta Region One explained that the Métis are not opposed to developments, and in fact they look to business opportunities, but they are concerned about environmental impacts. • President of Métis Nation of Alberta Region One explained that there are approximately 15 businesses in the Lac La Biche area that may be interested in securing work with KNOC. He also mentioned that they are forming the Region 1 Métis Business Association. KNOC representative explained that KNOC would be interested in learning more about the Region 1 Métis Business Association and the Métis businesses that may be capable of providing goods and services to KNOC.
	October 15, 2009	Email	<ul style="list-style-type: none"> • KNOC representative sent President of Métis Nation of Alberta Region One an email. • Email contained the KNOC BlackGold Expansion Project plain language summary and project summary table. • Email also explained that KNOC would like to receive information on Métis businesses.
Mr. Bill Martin, Trapline Holder	February 7, 2008	Meeting	<ul style="list-style-type: none"> • Discussed consultation process preferred by Mr. Bill Martin, Trapline holder. • Discussed potential business opportunities for a contracting company owned by Bill Martin (George Quintal, company manager, also in attendance). • Made contact with Mr. Bill Martin regarding distributing firewood to Conklin Community Seniors for winter.

Participant	Date	Method	Discussion Points
Mr. Bill Martin, Trapline Holder (cont)	December 3, 2008	Telephone	<ul style="list-style-type: none"> • KNOC Representative called Bill Martin. • KNOC Representative explained that KNOC had previously met with Bill Martin to discuss the project and that the last meeting occurred on February 7, 2008. • KNOC representative asked if Bill was interested in an update or interested in meeting. • Bill Martin stated that he had received and read a copy of the application which was submitted to AENV and the ERCB and that he had some questions for KNOC and would like to meet. • A meeting was agreed to in Conklin on December 9, 2008. • KNOC Representative asked what kinds of questions Bill had for KNOC, so that they could hopefully provide him answers at the meeting. Bill stated that he was mostly interested in employment and contract opportunities. • KNOC Representative reminded Bill Martin that KNOC had provided his company with a contract last year and would determine if it was feasible to provide further opportunities in 2009.
	December 9, 2008	Meeting	<ul style="list-style-type: none"> • Bill Martin confirmed that he had received copies of the applications that KNOC had submitted to AENV and the ERCB and had reviewed them. • KNOC Representative provided hardcopies of the KNOC BlackGold Overview Presentation to Bill Martin and David Harris. Bill Martin explained that he remembered seeing this presentation at the last meeting. KNOC Representative explained that the presentation had been updated and highlighted the updates. • Bill Martin stated that he did not have any issues and concerns with the project proceeding. He explained that he was looking for business opportunities. • KNOC Representative asked Bill Martin to send a list of Bill Martin's Contracting capabilities. Bill stated that he would send it once it has been updated. • Bill explained that he can do wood salvage work and will soon have a track hoe. • KNOC representative reminded Bill Martin that KNOC had given Bill Martin Contracting a contract to do tree clearing in early 2008, and asked if he would be interested in similar work this year. Bill Martin replied that he would like a similar contract.
	December 10, 2009	Fax	<ul style="list-style-type: none"> • Faxed Bill Martin a contract to complete some tree clearing.
	February 12, 2009	Telephone	<ul style="list-style-type: none"> • Phoned Bill Martin to confirm that he received fax sent on February 10, 2009. Bill Martin confirmed that he received the fax. Bill Martin also confirmed that he agreed to the contract and was interested in completing the work.
	October 16, 2009	Telephone	<ul style="list-style-type: none"> • KNOC representative tried to contact Bill Martin on both his landline and cell phone. Both numbers were disconnected.
	October 16, 2009	Telephone	<ul style="list-style-type: none"> • KNOC representative left a message for Manager of Bill Martin's business requesting that he return the call.

Participant	Date	Method	Discussion Points
Mr. Bill Martin, Trapline Holder (cont)	October 16, 2009	Telephone	<ul style="list-style-type: none"> • George Quintal returned KNOC representatives telephone call. • KNOC representative explained that he was trying to contact Bill Martin. • Business Manager explained that he still works for Bill Martin and provided a new telephone number for Bill Martin. • Business Manager also asked about the status of the KNOC BlackGold Project. KNOC representative provided an update and explained that KNOC will be applying for an expansion of their project.
	October 16, 2009	Telephone	<ul style="list-style-type: none"> • KNOC representative called Bill Martin and left a message requesting that Bill Martin return the call.
	October 16, 2009	Telephone	<ul style="list-style-type: none"> • Bill Martin returned KNOC representatives call. • Bill Martin explained that he has a new company, called Martin's General Contracting and new contact information. • Bill Martin inquired about whether KNOC would have any work for him. KNOC representative explained that KNOC is awaiting approval for their project and explained that if it is approved, work may commence this winter. KNOC representative explained that he would inform KNOC that Martin's General Contracting was interested in work and ensure that KNOC responded. • KNOC representative also explained that KNOC was applying for an expansion project and explained that they had produced a plain language summary and project summary sheet. Bill Martin asked that the information be mailed to him.
	October 16, 2009	Letter	<ul style="list-style-type: none"> • KNOC representative sent a letter containing Plain Language Summary and Project Summary Sheet to Bill Martin.